



The Specialists for Filters
in Marine and Industry

www.fil-tec-rixen.com





Success through Progress

For over 30 years, the filter specialist FIL-TEC RIXEN GmbH has been involved with the improvement, manufacture, service, and sales of filters and filter replacement parts for marine and industrial applications.

The technical improvements needed for extending the service life of candle filters and filter elements, which were implemented with the introduction of the Fil-Tec filter elements, are based on 30 years of practical experience and analysis. The ongoing training of our engineers and our service staff and the regular contact with shipping companies and the responsible engineers onboard ships and in the manufacturing industry allow FIL-TEC to respond at short notice and with great flexibility to every conceivable kind of problem.

Just this combination of experience and the use of state-of-the-art production methods and control systems is what ensures the high technical standard of Fil-Tec candle filters and filter elements.

This brochure provides an overview of the corporate philosophy of FIL-TEC RIXEN. We are pleased to present the diversity of our products and services in a snapshot. But that's not to say that the advancements and improvements have stopped here; we are continuing to forge our way ahead. The FIL-TEC RIXEN GmbH is eager to convey to its customers its sense of responsibility for its performance and the pursuit of improvements, because ultimately this is what makes progress and success possible in the first place.

Dipl.-Ing. O. Rixen
CEO

Table of Contents

Page 3	Success through Progress	Page 84	Candle filter inserts
Page 5	Our philosophy	Page 85	Basket elements
Page 6	Individual solutions – and flexibility	Page 86	Ring element
Page 8	From component – to assembly	Page 87	Candle filters - elements for automatic filters
Page 10	Reliable products guarantee security – all over the world	Page 88	Filter components and accessories
Page 12	The variety of FIL-TEC RIXEN GmbH – is encountered simply everywhere	Page 90	Fil-Tec disposable elements
Page 14	Worldwide service around the clock	Page 91	Control systems for automatic filters
Page 15	Delivery	Page 92	Fil-Tec production and major overhaul of complete filters
Page 16	FIL-TEC RIXEN GmbH stands for quality	Page 93	Replacement filter elements for Nantong
Page 17	DNV-GL-Certification of FIL-TEC RIXEN- replacement filter elements for single-, double- and automatic-filter	Page 94	Replacement filter elements for Kanagawa Kiki
Page 18	FIL-TEC RIXEN represents the future	Page 95	Problems with notch wire filter elements
Page 20	Sleeve basket filter FTMF	Page 96	Filter elements and replacement parts for automatic filters made in Italy
Page 24	Strainer basket filter FTSF	Page 97	Filter elements to match Moatti filters
Page 28	Single filter FTWF	Page 98	Water filter cartridges, housings and complete systems
Page 32	Single filter FTWF-Inline	Page 99	Fil-Tec air filters
Page 35	Bag filter / strainer FTBF	Page 100	Paint and drying technology
Page 38	Multi-bag filter FTBF-M	Page 101	Filter cartridges for lubricating oil and fuel
Page 42	Filter bags	Page 102	Filter elements for lubricating oil and fuel produced by Fil-Tec
Page 44	Type approval for seawater filters made by FIL-TEC RIXEN	Page 103	Hydraulic filter elements
Page 45	Fil-Tec filter housing series FT06	Page 104	Filter elements produced on the basis of a sample or drawing
Page 46	Duplex filter FTDF-K	Page 105	Oil separation cartridges and accessories
Page 52	Duplex filter FTDF-V	Page 106	Mobile filtration
Page 56	Ball cock change-over filter FTDWF	Page 107	Presentation of a gear unit oil filtration system
Page 58	Duplex filter FTDFDN65	Page 108	Centrifugal oil cleaner FM 400/600/200
Page 60	FTAF Bernoulli Self-Cleaning Automatic Filter	Page 113	FIL-TEC RIXEN Training and Demonstration Centre
Page 64	FTAF-S Bernoulli Self-Cleaning Automatic Filter	Page 114	Cost reduction through mobile free-jet centrifuge
Page 68	Backflush filter FTRF	Page 116	Fil-Tec ultrasonic units
Page 74	Fil-Tec differential pressure indicator	Page 120	Fil-Tec filter detergents
Page 75	Modern production of filter aids	Page 121	Fil-Tec cleaning tools
Page 77	Candle filters	Page 123	CAT FINES – a great risk
Page 82	Multi-mantle filter elements	Page 125	Engine damages increase more and more
Page 83	Pleated filter elements	Page 127	Company Information / Map



Our philosophy

The smooth functioning of plant, power and process engineering calls for a state of purity that is attained instantly. Only when this has been guaranteed in the form of high-quality filter elements is ecological and economical operation ensured. Filters are ubiquitous and used for everything imaginable.

Axiomatically, it means that filters are mass-produced articles. But to us, that doesn't mean that the quality has to suffer for it. Our mission and calling is to improve the living conditions of people by ensuring that systems operate properly, and that they are protected by effective filtration. Filtration, therefore, means safety for man and machines, because



- filtration protects nature and man against harmful substances
- filtration improves the quality of operating supplies in machinery, thus enhancing its utility and service life
- filtration helps to reduce the consumption of operating supplies, thereby ultimately improving efficiency and saving resources

FIL-TEC RIXEN GmbH is aware of this great responsibility and has the filtration know-how and qualifications necessary for fulfilling these criteria sufficiently. Through many years of exploring the factors that impact systems, and through fault detection and the analysis of interactions, we are now in the position to offer a wide range of filters offering functional reliability and security.

Purity and efficiency are our calling

Individual solutions



Thanks to our technically sophisticated management systems and flexibility when it comes to special orders, we can respond effectively and at short notice with customised solutions.

We not satisfied to just maintain this level of customer satisfaction, but rather, we want to build on it, because we adhere to a continuous improvement process.



and flexibility



Maritime shipping in particular is frequently subject to fluctuations in scheduling and unexpected problems onboard.

FIL-TEC RIXEN GmbH plays a pro-active role in this branch, marked by the utmost care and precision.

We also make an important contribution in the industrial sector, offering problem-oriented solutions.

From component



- FIL-TEC RIXEN stands for technical know-how
- We make sure that a vision becomes reality
- A dynamic team of engineers develops and improves the filtration process for maximum utilisation
- Experienced technicians and master craftsmen realise the ideas with the highest degree of accuracy and perfection

to assembly



Reliable products guarantee

security



FIL-TEC RIXEN offers not only its own products, but also filter elements from many other manufacturers as well as replacement parts for almost any type of filter, such as seals, valves, candles, etc., in perfect technical condition and at competitive prices.

– all over the world



The variety of FIL-TEC RIXEN GmbH



– is encountered simply everywhere

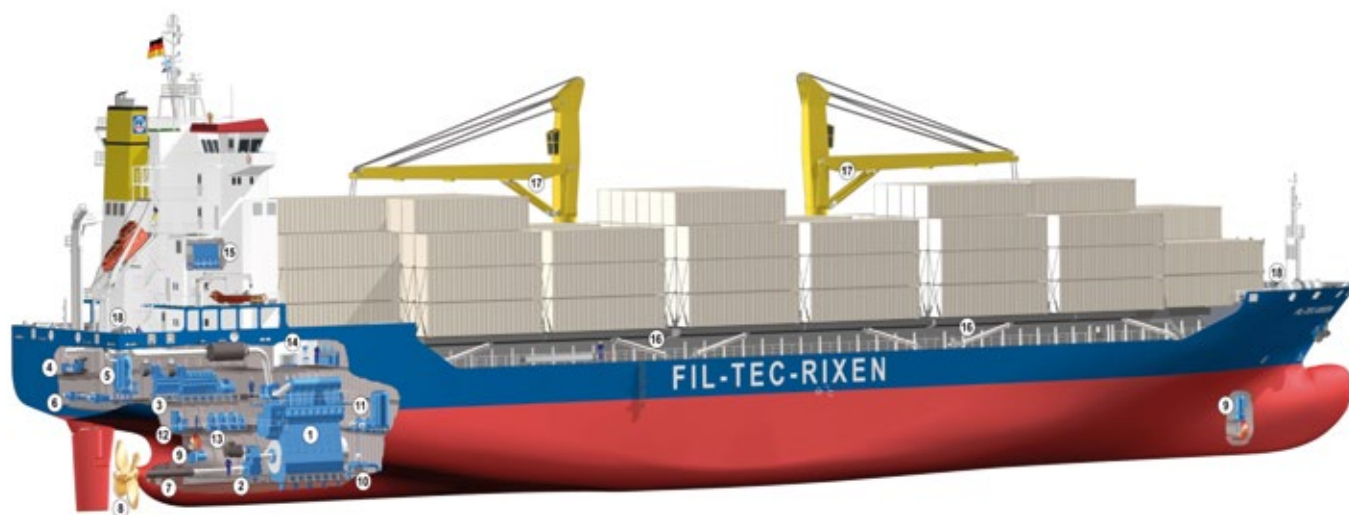

1 Main engine	7 Stern tube	13 Separators
2 Gears	8 Pitch propeller	14 Workshop
3 Auxiliary diesel	9 Bow & stern thrusters	15 Ventilation and air conditioning
4 Emergency diesel	10 Ballast water system	16 Hold hydraulic system
5 Boiler plant	11 Compressors	17 Crane hydraulic system
6 Rudder system	12 Bilge water separator	18 Winch hydraulic system



Worldwide service around the clock

The FIL-TEC RIXEN GmbH service department guarantees you individual service tailored to your needs and available around the clock. The technicians at FIL-TEC RIXEN are trained specialists and have learned the ins and outs of several filter manufacturers and their products. Consequently, we feel at home not only in shipping, but also in industry, where our customers include renowned automobile manufacturers, ship owners, and milling companies. Our technicians are at your service worldwide and are supported by numerous local representatives.

So if you should have problems with your filter systems, please do not hesitate to contact us.

Together we will find a solution!



FIL-TEC RIXEN GmbH
Protection System

Genuine Parts & Service

Tel.: +49 (0) 40 - 656 856 0 · info@fil-tec-rixen.com



Before – After



Delivery

FIL-TEC RIXEN cooperates with renowned forwarding agents (Hamburg Express, Schenker Euro Cargo, Dachser) and courier services (UPS, TNT and DHL Worldwide).

FIL-TEC RIXEN GmbH ships up to 150 consignments daily worldwide. Try us, and we guarantee you will not be disappointed by the trust you invest in us and our shipping partners.



DNV-GL-Certification of FIL-TEC RIXEN-replacement filter elements for single-, double- and automatic-filter



For more than 30 years, the filter specialist **FIL-TEC RIXEN GmbH** has been involved with the improvement, manufacture, service and sales of filters and filter replacement parts for marine and industrial applications of **nearly all important original manufacturers**.





Job security, conserving the natural environment and the livelihoods of future generations, and continuously improving working conditions in all departments of FIL-TEC RIXEN GmbH are important issues for the management.

Our environmental policy includes:

- responsible management of natural resources
- efficient energy use
- efficient use of raw materials
- waste minimisation
- risk prevention

Measures taken in recent years:

- constructing an energy-efficient warehouse and workshop, phase 1 / 2011
- using the latest vehicle technology throughout our vehicle fleet
- converting warehouse and office space to LED lighting
- warehouse and workshop expansion, phase 2 / 2016
- using the latest machining centres to optimise processing times
- linking CAD development and manufacturing
- using simulation software for product development instead of using models
- installing a photovoltaic system to power the warehouse and workshops, as well as offices, 3rd quarter of 2016
- purchasing an electric vehicle for short distances and city trips, 4th quarter of 2016



FIL-TEC RIXEN represents the future

We take our responsibility for future generations seriously – and are a registered training company with the Hamburg Chamber of Crafts and the Hamburg Chamber of Commerce and Industry.



FTMF

SLEEVE BASKET FILTER

G 1/2" – 2 1/2"

PN 10 – PN 16



Applications

The FTMF filter is a versatile strainer basket filter for gaseous and liquid media made from GGG-50 (nodular graphite) in accordance with EN-GJS-500-7 or Rg 10, (special version). It is characterized by high performance, low weight and space-saving design, as well as an extremely easy, fast cleaning.

- **Flexible combination of housing sizes, filter surfaces and connecting sleeves.**
Eleven housing sizes can be supplied with different connecting sleeves, which ensures adaptation to the operating requirements and quantities of impurities.
- **Variable filter surface selection.**

Brief description

The filter consists of a cast housing with opposing connecting sleeves of equal height. The filter cover is alternatively fastened with stud bolts and nuts. The venting device in the cover and drain unit in the housing are included in the scope of supply.

- **Quick-acting clamp for cleaning the strainers.**

Filter media

Alternatively the filter can be equipped with a basket strainer, ring or other inserts. For example the filter insert consists of perforated plate, which is optionally spanned with mesh of different widths. The medium to be filtered flows through the strainer insert from the inside to the outside. The particles remain in the strainer and can be removed with the strainer.



Safety instructions

Do not use the filter with clamp catch for filtering of hazardous media (e.g. toxic, flammable, or corrosive media) and gases or vapors! In these cases select bolts and nuts for the cover catch. Prior to using the filter verify the intended use. If there are changes in operating conditions or the medium then a conformity

evaluation in accordance with PED EN 97/23 EC must be carried out (for this please contact us as the manufacturer or execute a hazard analysis with conformity evaluation).

Installation

Installation in pipes is carried out using sleeve connections. Ensure that the standard version of the filter is installed and in a mechanically tension-free manner without additional loads. The medium must flow in the direction specified on the housing. Incorrect installation can cause filter malfunctions and damage the inserts.

Commissioning / operating instructions

1. Open the venting device until liquid escapes
2. Close venting device
3. Filter is ready for operation

Attention: Since this is a pressure vessel make absolutely sure that the filter is depressurized before starting maintenance tasks. Follow the safety and accident prevention guidelines required for the medium.

Cleaning

1. Relieve the pressure on the filter by means of the venting device and drain unit.
2. Loosen the filter catch and lift off the cover
3. Drain the filter via the drain unit to a level that is at least below the strainer support.
4. Pull the strainer insert upward and out of the filter housing. The strainer can now be cleaned by careful blowing it out or blasting it with compressed air, steam, or water. If necessary the strainer must be soaked and cleaned in a suitable cleaning agent. In some circumstances optimum cleaning is achieved by means of ultrasound. For all cleaning types ensure that the filter mesh is not damaged.
5. When assembling the filter in the reverse sequence, check the sealing elements for wear and replace them if necessary.

Technical data

	Standard version	Special version or supplemental equipment
Filter insert	Strainer insert or ring strainer	Double strainers, cartridges
Filter mesh	20 – 1,000 µm (microns) Stainless steel mesh 1,5 – 10 mm perforated plate, round pitch	5 µm, square perforation, braid, cartridges, pleated mesh
Filter catch	G 1/2" – G 2 1/2" combination cover with clamp catch or cover with bolts and nuts. Housing with clamp already predrilled for stud bolts – upgrade by customer possible.	
		Fig. 2: Clamp, david
Venting device	Bolt, G 1/4"	Ball valve
Draining unit	Bolt, G 3/8"	Ball valve
Connection	Pipe female thread, Withworth	With welded-on ends
Materials:		
Housing and cover	GGG-50, DN 1693 DIN EN 1563 or EN GJS-500-07	Rg 10, GGG-40.3 (EN GJS-400-18)
Cover seal	NBR	FPM, EPDM, MPQ, PTFE
Perforated plate/mesh	1.4401, 1.4301, 1.4301/1.4401	1.4571/1.4401, Ms/Bz, Hastelloy C 4, various plastics
Additional filter	-	Magnetic filter insert
Heater	-	Steam, hot water or electrical heater
Zinc protection	-	For sea water filters
Differential pressure indicator	Connection possibility G 1/4"	Optical, electrical
Housing Surface treatment	Inside anti-corrosion primer	Untreated, anti-corrosion oil, epoxy resin, Vulcanite rubberlined, E-CTFE, Levasynt, Belzona 2011
	Outside epoxy paint RAL 5010 blue	Epoxy resin, E-CTFE, Levasynt , customer RAL
Design/Certification	Declaration of Conformity, 3.1 Material Certificates – Lloyds Register certified foundry acc. to DGRL 97/23/EC (CE)	on request

Connections for
Fil-Tec differential pressure indicator/switch

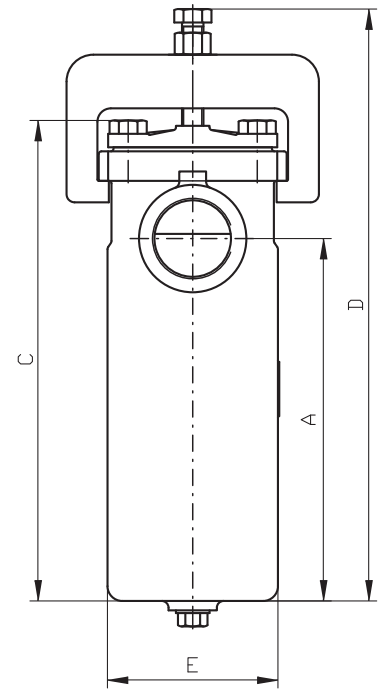
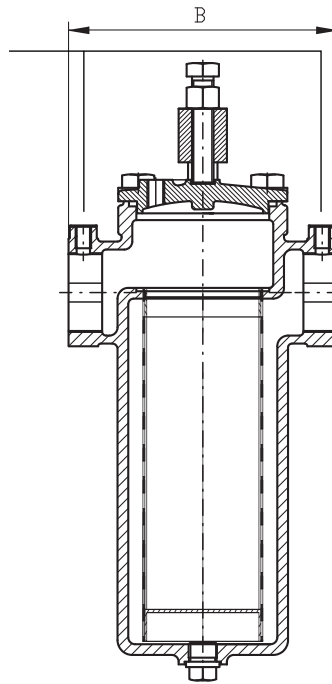

Technical data and dimensions

	Nom. diameter	Design pressure		E Ø	A mm	B mm	C mm	D mm	Flow rate at 2,5 m/s m ³ /h	Content l	Filter surface area		Weight approx. in kg
		Clamp bar	Bolts bar								Basket cm ²	Ring cm ²	
GR1	G 1/2				150		261	326	3	2	260	390	6
	G 3/4								3				
	G 1								4,5				
	G 1 1/4								7				
GR2	G 1/2	10	16	127	208	230	308	384	3	2,5	485	730	8
	G 3/4								3				
	G 1								4,5				
	G 1 1/4								7				
GR3	G 1 1/2				268		379	444	12	3	560	840	9
	G 2								18				
GR4	G 1 1/2				393		504	569	12	4,2	870	1300	10
	G 2								18				
	G 2 1/2								30				

On request we manufacture and ship additional design and material variants.

Please send your enquiry.

FTSF

STRAINER BASKET FILTER DN 15 – DN 600 | PN 6 – PN 25 ANSI 1 1/2 – 24" OR JIS



Applications

The FTSF filter is a versatile strainer basket filter for gaseous and liquid media made from GGG-50 (nodular graphite) in accordance with EN-GJS-500-7 or Rg 10, (special version). It is characterized by high performance, low weight and space-saving design,

- as well as an extremely easy, fast cleaning.
Flexible combination of housing sizes, filter surfaces and connecting flanges.
Eleven housing sizes can be supplied with different
- connecting flanges, which ensures adaptation to the operating requirements and quantities of impurities.
Variable filter surface selection.

Brief description

The filter consists of a cast housing with opposing connecting flanges of equal height. The filter cover is alternatively fastened with stud bolts and nuts.

- The venting device in the cover and drain unit in the housing are included in the scope of supply.
Quick-acting clamp for cleaning the strainers (to DN 200).

Filter media

Alternatively the filter can be equipped with a basket strainer, ring or other inserts. For example the filter insert consists of perforated plate, which is optionally spanned with mesh of different widths. The medium to be filtered flows through the strainer insert from the inside to the outside. The particles remain in the strainer and can be removed with the strainer.

Safety instructions

Do not use the filter with clamp catch for filtering of hazardous media (e.g. toxic, flammable, or corrosive media) and gases or vapors! In these cases select bolts and nuts for the cover catch. Prior to using the filter verify the intended use. If there are changes in operating conditions or the medium then a conformity evaluation in accordance with PED EN 97/23 EC must be carried out (for this please contact us as the manufacturer or execute a hazard analysis with conformity evaluation).



Installation

Installation in pipes is carried out using flanges. Ensure that the standard version of the filter is installed and in a mechanically tension-free manner without additional loads. The medium must flow in the direction specified on the housing. Incorrect installation can cause filter malfunctions and damage the inserts.

Commissioning / operating instructions

1. Open the venting device until liquid escapes
2. Close venting device
3. Filter is ready for operation

Attention: Since this is a pressure vessel make absolutely sure that the filter is depressurized before starting maintenance tasks. Follow the safety and accident prevention guidelines required for the medium.

Cleaning

1. Relieve the pressure on the filter by means of the venting device and drain unit.
2. Loosen the filter catch and lift off the cover.
3. Drain the filter via the drain unit to a level that is at least below the strainer support.
4. Pull the strainer insert upward and out of the filter housing. The strainer can now be cleaned by careful blowing it out or blasting it with compressed air, steam, or water. If necessary the strainer must be soaked and cleaned in a suitable cleaning agent. In some circumstances optimum cleaning is achieved by means of ultrasound. For all cleaning types ensure that the filter mesh is not damaged.
5. When assembling the filter in the reverse sequence, check the sealing elements for wear and replace them if necessary.

Heat flanges and differential pressure indicator

On request the filter can be fitted with heat flanges in the floor area as shown in the sketch. The use of heaters requires the use of ring strainers.

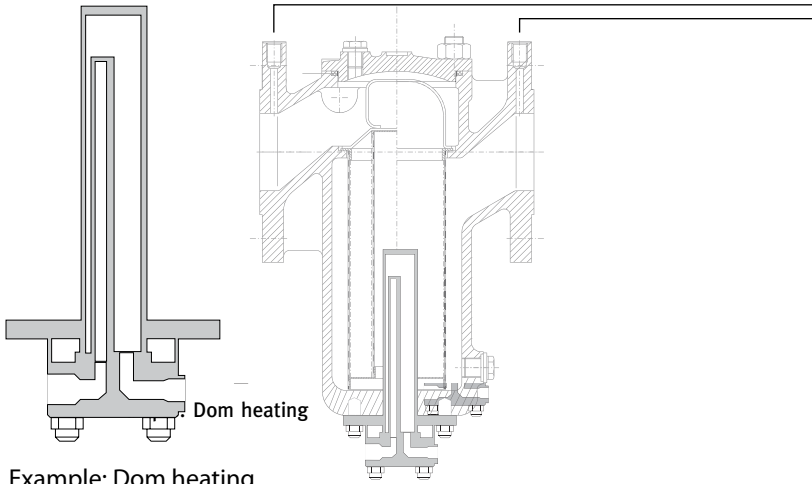

Connections for differential pressure indicator/switch



Example: Dom heating



FTSF filter with differential pressure indicator



The FTSF „family“ from size 1 to size 11

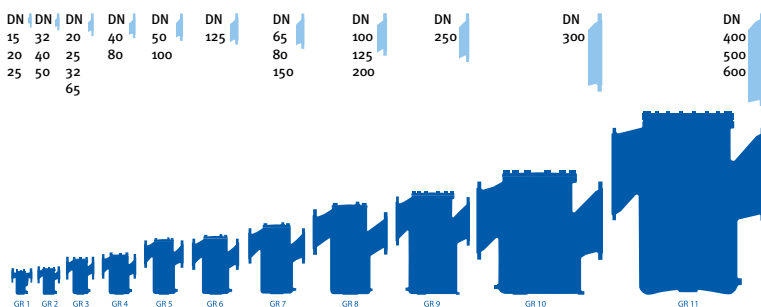

Technical data

	Standard version	Special version or supplemental equipment
Filter insert	Strainer insert or ring strainer	Double strainers, cartridges
Filter mesh	20 – 1,000 µm (microns) Stainless steel mesh 1,5 – 10 mm perforated plate, round pitch	5 µm, square perforation, braid, cartridges, pleated mesh
Filter catch	DN 15 - 200 combination cover with clamp catch or cover with bolts and nuts. Housing with clamp already predrilled for stud bolts – upgrade by customer possible. From DN 250 bolts and nuts.	
		Fig. 2: Clamp, david
Venting device	Bolt, G 1/4"	Ball valve / Flange / SW*
Draining unit	Bolt, G 3/8"	Ball valve / Flange / SW*
Connection	Flange in accordance with DIN 2532/ Shape B	As specified by the customer (ANSI) or JIS
Materials:		
Housing and cover	GGG-50, DN 1693 DIN EN 1563 or EN GJS-500-07	Rg 10, GGG-40.3 (EN GJS-400-18)
Cover seal	NBR	FPM, EPDM, MPQ, PTFE
Perforated plate/mesh	1.4401, 1.4301, 1.4301/1.4401	1.4571/1.4401, Ms/Bz, Hastelloy C 4, various plastics
Additional filter	-	Magnetic filter insert
Heater	-	Steam, hot water or electrical heater
Zinc protection	-	For sea water filters
Differential pressure indicator	Connection possibility G 1/4"	Optical, electrical
Housing Surface treatment	Inside anti-corrosion primer	Untreated, anti-corrosion oil, epoxy resin, Vulcanite rubberlined, E-CTFE, Levasynt, Belzona 2011
	Outside epoxy paint RAL 5010 blue	Epoxy resin, E-CTFE, Levasynt, customer RAL
Design	PED 97/23 EG (CE) Declaration of Conformity	3.1 Certificates

*Depends on size of body

Standard Connections for differential pressure indicator/switch G 1/4"

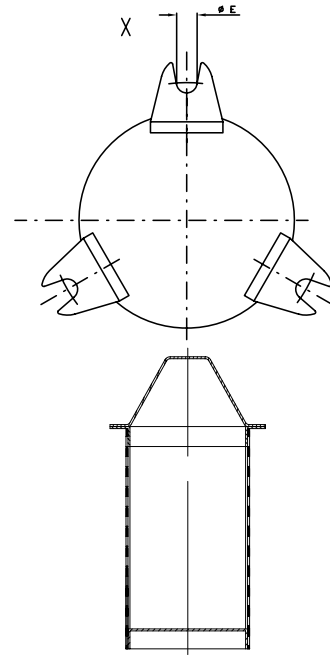
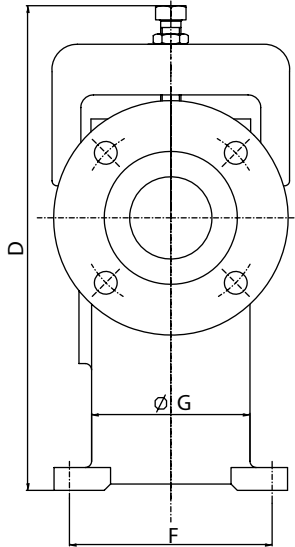
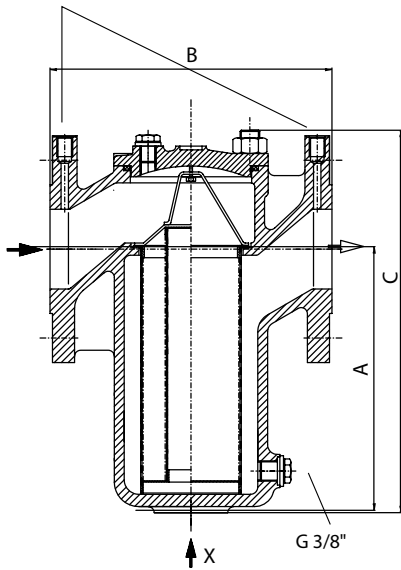

FTSF combination version (clamp version pre-drilled), can be converted by using stud bolts.

Basket strainer

Housing	Nom. diameter Flange connection	Design pressure		G	A	B	D	C	E	F	Content		Filter surface area	Weight
Size	DN	Clamp	Bolts**				Clamp	Bolt	Diameter	Pitch	at 2,5 m/s		Basket	
mm	mm	bar	bar	mm	mm	mm	mm	mm	mm	mm	m ³ /h	l	cm ²	approx. in kg
1	15	16	16	81	156	171	264	220	Without feet		3	1	150	6
	20	16	16	81	156	171	264	220			3	1	150	6
	25	16	16	81	156	171	264	220			4,5	1	150	6
2	32	10	16	102	164	189	340	270	Without feet		7	1,2	270	15
	40	10	16	102	164	189	340	270			12	1,2	270	15
	50	10	16	102	164	189	340	270			18	1,2	270	15
3	20	10	16	127	214	219	400	355	12	161	3	3,5	440	25
	25	10	16	127	214	219	400	355	12	161	4,5	3,5	440	25
	32	10	16	127	214	229	400	355	12	161	7	3,5	440	25
	65	10	16	127	214	229	400	355	12	161	30	3,5	440	25
4	40	10	16	168	229	279	450	380	12	201	12	6,5	740	28
	80	10	16	168	229	279	450	380	12	201	45	6,5	740	28
5	50	10	16	168	324	317	570	450	14	216	18	9	950	42
	100	10	16	168	324	317	570	450	14	216	70	9	950	42
6	125	6	10	222	324	379	590	540	14	261	110	15	1.350	55
7	65	6	10	262	389	461	720	620	18	311	30	27	1.980	75
	80	6	10	262	389	461	720	620	18	311	45	27	1.980	75
	150	6	10	262	389	461	720	620	18	311	160	27	1.980	75
8	100	6	10	322	489	597	890	770	23	371	70	53	2.950	140
	125	6	10	322	489	597	890	770	23	371	110	53	2.950	140
	200	6	10	322	489	597	890	770	23	371	280	53	2.950	140
9	250	-	10	402	599	604	-	925	23	460	440	85	3.590	195
10	300	-	6 (10)*	472	719	719	-	1.075	23	530	635	140	5.610	300
11	400	-	6 (10)*	790	1.000	1.246	-	1.500	33	966	1.130	600	16.000	1400
	500	-	6 (10)*	790	1.000	1.246	-	1.500	33	966	1.770	600	16.000	1400
	600	-	6 (10)*	790	1.000	1.246	-	1.500	33	966	2.545	600	16.000	1400

* Special version

**For screws dependent on DN and medium to PN 25

FTWF

SINGLE FILTER DN 15 – 1000, STEEL, STAINLESS STEEL, PLASTIC, GFK

Areas of application

The FTWF single filter is a versatile implementation filter for liquid, gaseous or pasty media. It is characterized by high-performance, low spatial requirements, as well a possibility for fast and easy cleaning. Inlet and outlet flange can be positioned as desired as special version (in the standard version height offset).

Brief description

In the standard version the filter consists of a welded steel vessel with cover that is fastened through screws and nuts. Alternatively the filter can be equipped with a strainer, ring strainer insert or cartridges, or bag filters.

Installation

The filter is installed in piping via flanges. Ensure that the standard version of the filter is installed vertically, tension-free without additional mechanical stress. The medium must flow in the direction specified on the vessel. Incorrect installation can cause filter malfunctions or damage.

Commissioning / operating instructions

1. Slowly open the inlet/outlet valves.
2. Open the vent until liquid escapes.
3. Close vent.
4. Filter is ready for operation.

Cleaning

Attention: Since in this case a pressure vessel is involved, strictly ensure that the vessel is without pressure before starting maintenance tasks. Comply with the safety and accident prevention guidelines required for the medium.

1. Depressurize the filter via vent and drain with the drain connection.
2. Loosen the vessel opening and take off the cover.
3. Empty the filter via the drain to a level that is at least below the strainer support.



Germanischer Lloyd



Lloyd's Register



CERTIFICATION:
GL, LR, DNV, ABS



	Materials (standard version)	
Vessel	St 35.8/P265 GH; 1.4541, 1.4571, Hastelloy, special materials, plastic PE, PP, PVDF, GFK/FRP	
Filter medium strainer insert	Perforated plate with stainless steel mesh, cartridges, bags	
Nominal diameter DN	Design pressure PN standard - higher PN on request	
15 – 50	25	16 Filter opening clamp or bolts and nuts
65 – 100	16	10 Filter opening clamp or bolts and nuts
125 – 300	16	
300 – 1.000	16	

On request approval in accordance with DGRL 97/23 EG (CE), approval in accordance with module G through TÜV

4. Pull the strainer insert upward and out of the filter vessel. The strainer can now be cleaned by carefull blowing it out or blasting it with compressed air, steam, or water. If necessary the sieve must be soaked and cleaned in a suitable agent. Under some circumstances optimal sieve cleaning is achieved through ultrasound. For all cleaning types ensure that the filter mesh is not damaged.
5. When assembling the filter check the cover seal for wear, replace it if necessary.
6. If the medium is changed a conformity evaluation in accordance with PEN 97/23 EG CE must be executed.



Technical data

	Standard version	Special version or supplemental equipment	
Filter insert	Strainer insert	Ring strainer insert double strainer	Double strainers, pleated strainer insert, cartridges, bags
Degree of filtration	10 - 1000 µm; > 1 mm: perforated plate with round perforation		
Filter opening	Screws with nuts (Fig. 1)	Clamp, david etc.	
Vent	Screw	Ball valve	
Drain	Screw	Ball valve	
Connection	Height-offset according to the design pressure of the filter inlet and outlet	As specified by the customer	
Materials:			
Vessel and cover	St 35.8, P 265 GH, 1.4541, 1.4571	Various plastics such as PP, PE, PVDF, GFK	
Filter opening	In accordance with the vessel material	-	
Cover seal	Asbestos-free flat seal	O-ring: NBR, FPM, EPDM, MPO, PTFE	
Perforated plate/mesh	St, St/1.4401, 1.4301, 1.4301/1.4401	1.4571/1.4401, MS/Bz, Hastelloy C 4, various plastics	
Attachment parts	VA		
Supplemental filter	-	Magnetic filter insert	
Heater	-	Steam, hot water or electrical heater	
Differential pressure indicator	-	Optical, electrical	
Surface treatment interior:			
Vessel steel	Preservation oil	Corrosion protection lacquer, epoxy resin, E-CTFE, other paint	
Vessel stainless steel	Etched and passivated, glass-shot blasted	Electro-polished	
Vessel plastic PP, PE, PVDF, GFK/FRP			
Surface treatment exterior:			
Vessel steel	Synthetic resin lacquer, RAL 5010 blue	Rubberlined, epoxy coated, glassflake coated as well as customer-specific	
Vessel stainless steel	Glass-shot blasted	Pickled and passivated	

We manufacture and deliver additional design and material variants on customer request.

We request your enquiry.



FTWF in stainless steel 1,4571



40x FTWF series cartridge filter

Technical data and dimensions

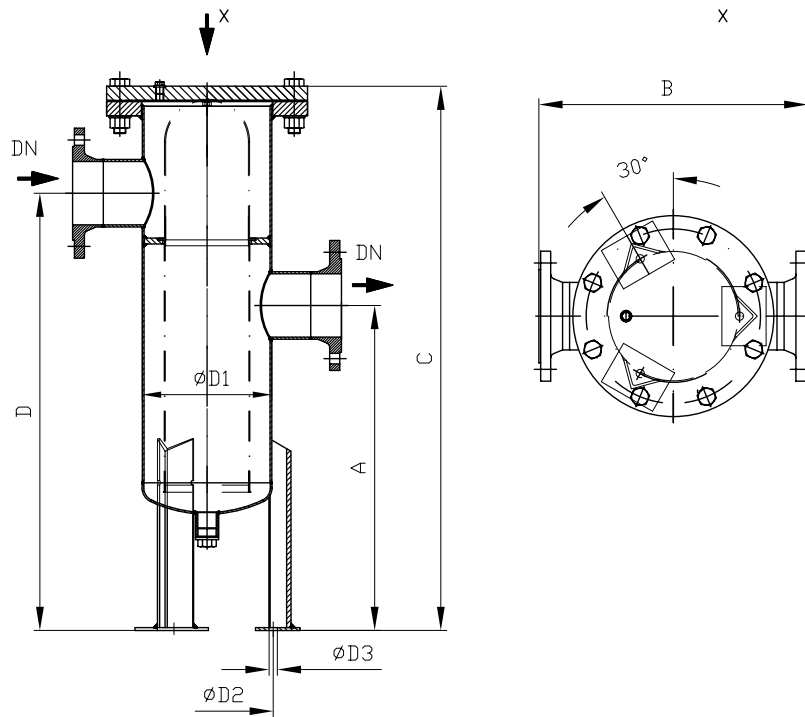

Fig. 1: Standard version FTWF

DN	Housing Size	PN	ØD1	ØD2	ØD3	D	A	C	B	Contents approx.	Flow rate	Filter surface approx.	Weight approx.
mm	mm	bar	mm	mm	mm	mm	mm	mm	mm	dm ³	m ³ /h	cm ²	kg
15	1	16	114	ohne FüÙe	-	370	260	512	540	1	3	400	47,5
20	1	16	114	ohne FüÙe	-	370	260	512	540	1	3	400	47,5
25	1	16	114	ohne FüÙe	-	370	260	512	540	1	5	400	7,5
32	1	16	114	110	10	370	220	512	265	3,3	7	500	12,5
40	1	16	114	110	10	370	220	512	265	3,8	12	600	13,5
50	1	16	114	110	10	370	220	512	265	4,5	18	800	15,5
65	2	16	168	165	10	510	360	669	350	9,5	30	1.200	33
80	3	16	219	225	14	640	450	821	455	18,5	45	1.900	52
100	3	16	219	225	14	740	550	921	455	21,5	70	2.300	55
125	4	16	273	281	14	950	650	1.228	500	28	110	3.500	75
150	4	16	273	281	14	1.050	650	1.328	500	54	160	3.900	98
200	5	16	356	365	14	1.050	650	1.332	570	115	280	5.174	179
250	5	16	356	365	14	1.300	650	1.332	700	115	440	5.174	280
300	6	16	508	520	16	1.340	940	1.750	860	290	635	9.200	450
350	6												
400	7												
450	7												
500	8												
600	8												
700	9												
800	9												
1000	10												

Sizes on request



FTWF 1"

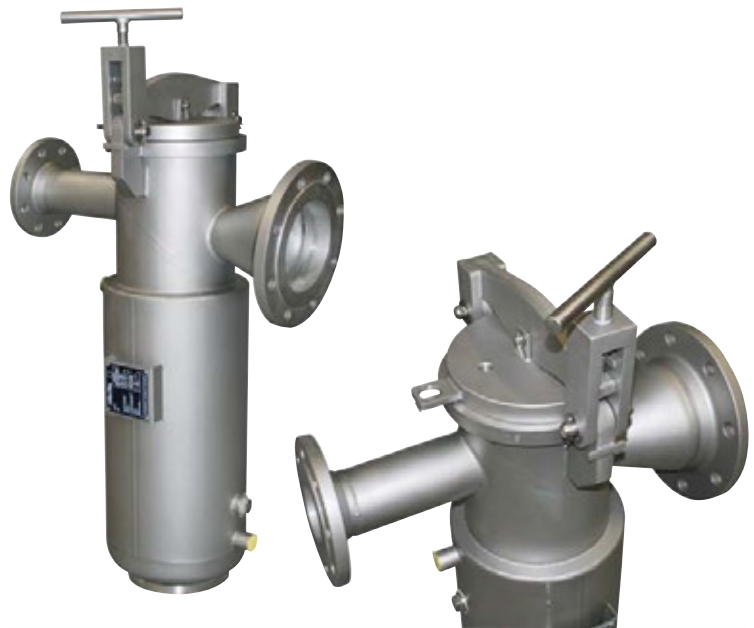

FTWF DN 150 with jacket heating



FTWF DN 500



FTWF DN 500 in GRP

FTWF-Inline

Single Filter
DN 15 – 1000, Steel, Stainless Steel
or GFK
PN 10 – PN 64

Areas of application

The FTWF-inline single filter is a versatile implementation filter for liquid, gaseous or pasty media. It is characterized by high-performance, low spatial requirements as well a possibility for fast and easy cleaning. Inlet flange and outlet flange are equal height.

Brief description

In the standard version the filter consists of a welded steel vessel with cover that is fastened through screws and nuts. Alternatively the filter can be equipped with a strainer, ringer strainer insert or cartridges, or bag filters.

Installation

The filter is installed in pipelines via flanges. Ensure that the standard version of the filter is installed vertically, tension-free without additional mechanical stress. The medium must flow in the direction specified on the vessel. Incorrect installation can cause filter malfunctions.

Commissioning / operating instructions

1. Slowly open the inlet/outlet valves.
2. Open the vent until liquid escapes.
3. Close vent.
4. Filter is ready for operation.

Cleaning

Attention: Since in this case a pressure vessel is involved, strictly ensure that the vessel is de-pressurized before starting maintenance tasks. Comply with the safety and accident prevention guidelines required for the medium.

1. Depressurize the filter via vent and drain.
2. Loosen the vessel opening and take off the cover.
3. Empty the filter via the drain to a level that is at least below the strainer support.



Germanischer Lloyd



CERTIFICATION:
 GL, LR, DNV, ABS



	Materials (standard version)	
Vessel	St 35.8/P265 GH; 1.4541, 1.4571, Hastelloy, special materials, plastic PE, PP, PVDF, GFK/FRP	
Filter medium Strainer insert	Perforated plate with stainless steel mesh, cartridges, bag	
Nominal DN	Design pressure PN Standard - higher PN's on request	
15 – 50	25	16 Filter catch with clamp
65 – 100	16	10 Filter catch with clamp
125 – 300	16	16 Quick-closing catches with cover swinging mechanisms
300 – 1.000	Filter catch with bolts and nuts on request	Medium-dependent quick-closing catches and cover swinting mechanisms

On request approval in accordance with DGRL 97/23 EG (CE), approval in accordance with module G through TÜV

4. Pull the sieve insert upward and out of the filter vessel. The strainer can now be cleaned by blowing it out or blasting it with compressed air, steam, or water. If necessary the sieve must be soaked and cleaned in a suitable agent. Under some circumstances optimal sieve cleaning is achieved through ultrasound. For all cleaning types ensure that the filter mesh is not damaged.
5. When assembling the filter check the cover seal for wear, replace it if necessary.
6. If the medium is changed a conformity evaluation in accordance with PEN 97/23 EG CE must be executed.

Technical data

	Standard version	Special version or supplemental equipment	
Filter insert	Strainer insert	Ring strainer insert double strainer	Double strainers, pleated strainer insert, cartridges, bags
Degree of filtration	10 - 1000 µm; > 1 mm: perforated sheet with round perforation (1 - 20 mm)		
Filter opening	Screws with nuts (Fig. 1)	Snap closings	
Vent	Screw	Ball cock	
Drain	Screw	Ball cock	
Connection	Height-offset according to the design pressure of the filter inlet and outlet		As specified by customer
Materials:			
Vessel and cover	St 35.8, P 265 GH, 1.4541, 1.4571	Various plastics such as PP, PE, PVDF, GFK	
Filter opening	In accordance with the vessel material	-	
Cover seal	Asbestos-free flat seal	O-ring: NBR, FPM, EPDM, MPO, PTFE	
Perforated plate/mesh	St, St/1.4401, 1.4301, 1.4301/1.4401	1.4571/1.4401, MS/Bz, Hastelloy C 4, various plastics	
Attachment parts	VA		
Supplemental filter	-	Magnetic filter insert	
Heater	-	Steam, hot water or electrical heater	
Differential pressure indicator	-	Optical, electrical	
Surface treatment interior:			
Vessel steel	Preservation oil	Corrosion protection lacquer, epoxy resin, E-CTFE	
Vessel stainless steel	Glass-shot blasted	Pickled and passivated, electro-polished	
Vessel plastic PP, PE, PVDF, GFK/FRP			
Surface treatment exterior:			
Vessel steel	Synthetic resin lacquer, RAL 5010 blue	Rubberized, epoxy coated as well as customer-specific	
Vessel stainless steel	Glass-shot blasted	Pickled and passivated	

We manufacture and deliver additional design and material variants on customer request.

We request your enquiry.



FTWF standard version



40x FTWF series
cartridge filter

Dimensions on request.

Technical data and dimensions

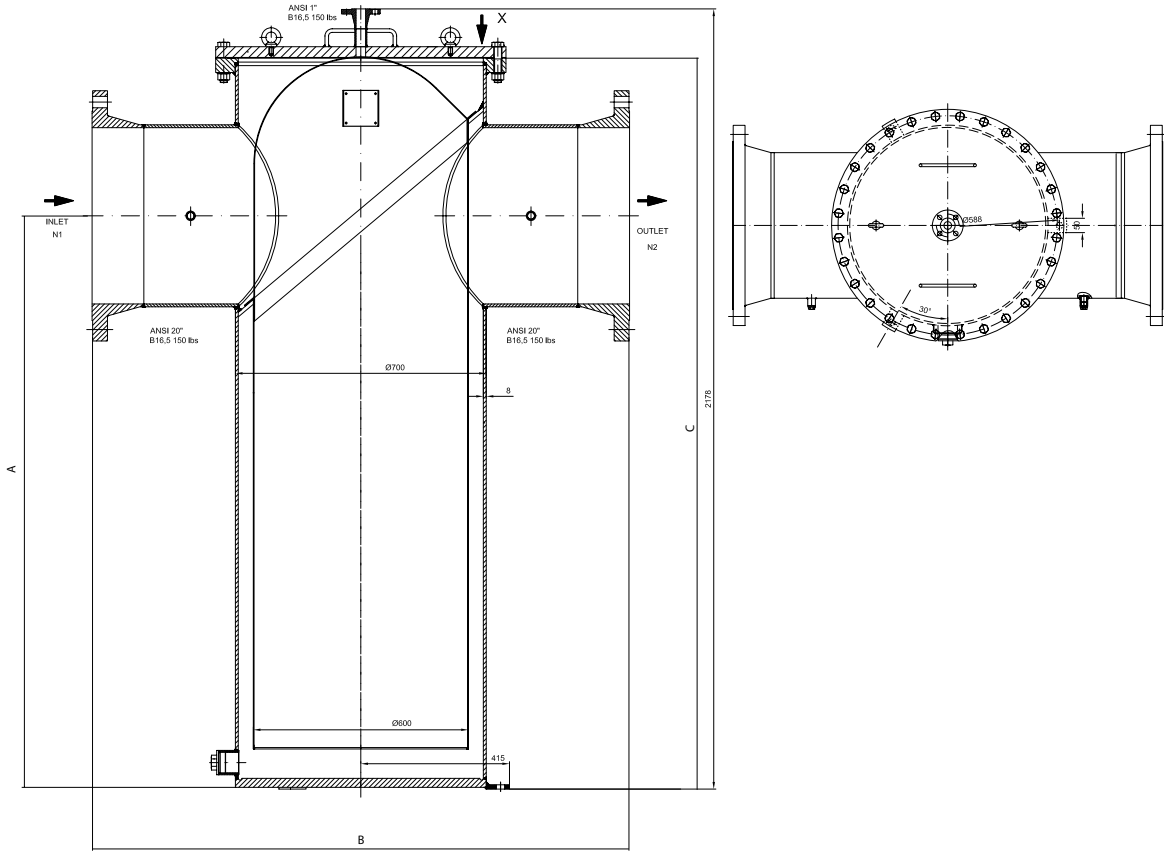

Fig. 1: Standard version FTWF-inline



DN	PN	ØD ₁	ØD ₂	ØD ₃	D	A	C	B	Contents approx.	Flow rate	Filter surface approx.	Weight approx.
mm	bar	mm	mm	mm	mm	mm	mm	mm	dm ³	m ³ /h	cm ²	kg
DN 15 – 1000												
Dimensions on request												



FTBF

Bag filter / strainer (Combination model) G2" (optional G3" / G4") or DN 50 (optional 80 / 100)



Application areas

The FTBF filter is used for the filtration of liquid media in industrial applications. Alternatively, the filter can be fitted with bags or a strainer insert. The filters are not approved for gases.

Brief description and function

FTBF series filters are available as side outlet (see Fig. 1 – 3) in a stainless steel version 1.4301 (SS304) and 1.4401 / 1.4408 (SS316). The filter consists of a filter vessel, height-adjustable frame (feet), strainer support, down-holding device and, optionally, the filter bag.

The medium enters the filter vessel through the side inlet and flows through a filter bag that is reinforced by a strainer support, from the inside to the outside. In addition to the recess and the down-holding device, the strainer support ensures that the filter bag is properly seated.

Installation

The filter is installed in pipes by threaded sockets or flanges. Ensure that the filter is installed in a mechanically stress-free manner without additional loads. The medium to be filtered must enter the filter vessel through the upper flange. Incorrect installation can cause filter malfunctions and damage the filter cartridge.

Attention: Since this is a pressure vessel, make absolutely sure that the filter is depressurized before starting maintenance tasks. Comply with the safety and accident prevention guidelines required for the medium.

Commissioning / operating instructions

1. Slowly open the inlet / outlet valves.
2. Open the venting device in the cover until liquid escapes (in case of hazardous liquids, according to the data sheet for hazardous substances and only using protective equipment or additional vent lines).
3. Close the venting device.
4. Filter is ready for operation.



Cleaning

Attention: Since this is a pressure vessel, make absolutely sure that the vessel is depressurized before starting maintenance tasks. Comply with the safety and accident prevention guidelines required for the medium.

1. Depressurize the filter by venting or draining device.
2. Loosen the vessel cover bolting or quick opening device and remove the cover.
3. Drain the filter by using the draining device until the fill level is at least just below strainer support.
4. Pull out the strainer insert with the bag filter upwards off the filter vessel. Replace the bag filter.
5. When re-assembling the parts, make sure that the sealing elements are intact; they must be replaced if necessary.
6. In case the medium or operating conditions are changed, a conformity assessment according to PED EN 97/23 EC CE must be carried out.

Technical data

	Standard version	Special versions or optional extras
Filter insert	Filter bag with strainer support	Cleanable strainer insert with stainless steel mesh
Filter mesh	All off-the-shelf bags 0.8–2,000 µm	Strainer insert 5–2,000 µm
Filter cap	Cover with eye bolts	-
Venting device	Screw/plug	Ball valve
Draining device	Screw/plug	Ball valve
Connection	Threaded sockets	Flange reducer, welded-on flange
Materials		
Housing and cover	1.4301/SS304/A2	1.4401/SS316/A4
Strainer support	1.4301/SS304/A2	1.4401/SS316/A4
Down-holding device	1.4301/SS304/A2	1.4401/SS316/A4
Cover seal	O-Ring: NBR	FPM, EPDM, PTFE
Eye bolt	1.4301/SS304/A2	-
Ring nut	1.4301/SS304/A2	-
Venting device	1.4301/SS304/A2	1.4401/SS316/A4
Draining device	1.4301/SS304/A2	1.4401/SS316/A4
Differential pressure display/cleaning display	Connections available	Visual, electrical
Surface interior	Glass bead blasted	electropolished
Steel housing		
Surface exterior	Glass bead blasted	electropolished
Steel housing		

On request, we manufacture and ship additional design and material versions.

Please send your enquiry.

Technical data and dimensions

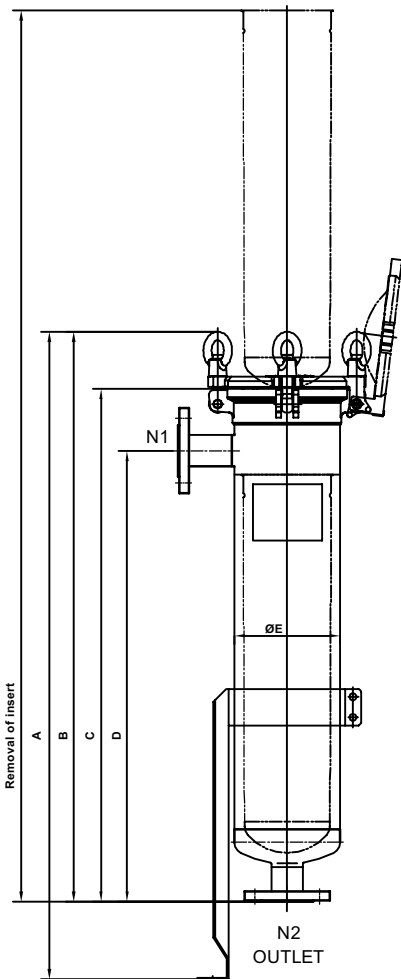
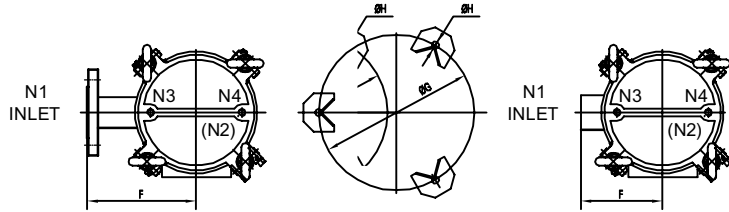

Fig. 1: Side outlet with flange

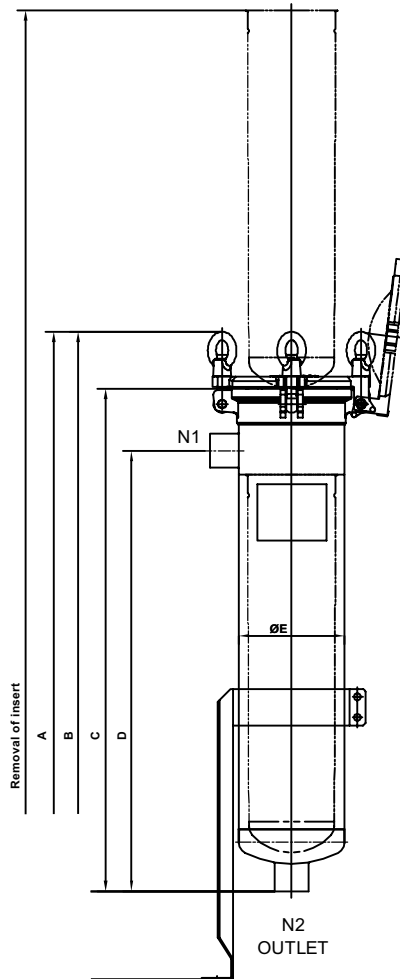

Fig. 2: Bottom outlet with flange

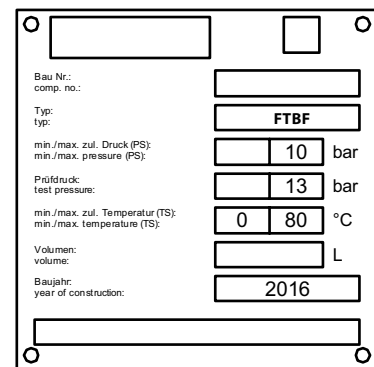

Fig. 3: Type plate example

	A	B	C	D	ØE	F	ØG	ØH	Removal of insert
Dimensions in mm									
Side-Outlet	1.249–1.439	1.099	990	885	200	210	300	14	1.720
Bottom-Outlet	1.229–1.419	1.079	970	865	200	158	300	14	1.700

FTBF-M

Multi-bag filter
DN 65–300 / ANSI 3–12"
PN 4–16



Application areas

The FTBF filter is used for the filtration of liquid media in industrial applications. Alternatively, the filter can be fitted with bags or a strainer insert. The filters are not approved for gases.

Brief description and function

FTBF series bag filters are available in 1.4301 (SS304) and 1.4401 / 1.4408 (SS316) stainless versions. The filter consists of a filter vessel, foot frame, strainer support, down-holding device and, optionally, the filter bag.

The medium enters the filter vessel through the side inlet and flows through a filter bag that is reinforced by a strainer support, from the inside to the outside. In addition to the recess and the down-holding device, the strainer support ensures that the filter bag is properly seated (Fig. 1).

Installation

The filter is installed in pipes by flange connections. Ensure that the filter is installed in a mechanically stress-free manner without additional loads. The medium to be filtered must enter the filter vessel through the upper flange. Incorrect installation can cause filter malfunctions and damage the filter cartridge.

Attention: Since this is a pressure vessel, make absolutely sure that the filter is depressurized before starting maintenance tasks. Comply with the safety and accident prevention guidelines required for the medium.

Commissioning / operating instructions

1. Slowly open the inlet / outlet valves.
2. Slowly open* the venting device in the cover until liquid escapes (in case of hazardous liquids, according to the data sheet for hazardous substances and only using protective equipment or additional vent lines).
3. Replace the filter bag.
4. Close the venting device.
5. Filter is ready for operation.

* For quick-release fasteners, observe the operating instructions supplied.



Example: 8-fold bag filter FTMF-M8 with quick-release fastener

Cleaning (quick guide)

Attention: Since this is a pressure vessel, make absolutely sure that the vessel is depressurized before starting maintenance tasks. Comply with the safety and accident prevention guidelines required for the medium.

1. Depressurize the filter by using the venting or draining device (Fig. 2) (See filter documentation).
2. Loosen the vessel cover bolting or quick opening device and remove the cover.*
3. Drain the filter by using the draining device until the fill level is at least just below strainer support.
4. Pull out the strainer insert with the filter bag upwards off the filter vessel. Replace the filter bag.
5. When re-assembling the parts, make sure that the sealing elements are intact; they must be replaced if necessary.
6. In case the medium or operating conditions are changed, a conformity assessment according to PED EN 97/23 EC CE must be carried out.

Technical data

	Standard version	Special versions or optional extras
Filter insert	Filter bag with strainer support	Cleanable strainer insert with stainless steel mesh
Filter mesh	All off-the-shelf bags 0.8–2,000 µm	Strainer insert 5–2,000 µm
Filter cap	Cover with eye bolts	Quick-release fastener
Venting device	Screw/plug	Ball valve
Draining device	Screw/plug	Ball valve
Connection	Threaded sockets	Flange reducer, welded-on flange
Materials		
Housing and cover	1.4301/SS304/A2	1.4401/SS316/A4
Strainer support	1.4301/SS304/A2	1.4401/SS316/A4
Down-holding device	1.4301/SS304/A2	1.4401/SS316/A4
Cover seal	O-Ring: NBR	FPM, EPDM, PTFE
Eye bolt	1.4301/SS304/A2	-
Ring nut	1.4301/SS304/A2	-
Venting device	1.4301/SS304/A2	1.4401/SS316/A4
Draining device	1.4301/SS304/A2	1.4401/SS316/A4
Differential pressure display/cleaning display	Connections available	Visual, electrical
Surface interior		
Steel housing	Glass bead blasted	electropolished
Surface exterior		
Steel housing	Glass bead blasted	electropolished

On request, we manufacture and ship additional design and material versions.

Please send your enquiry.

Technical data and dimensions

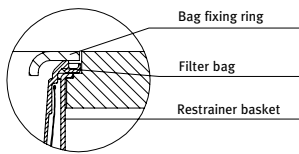

Fig. 1

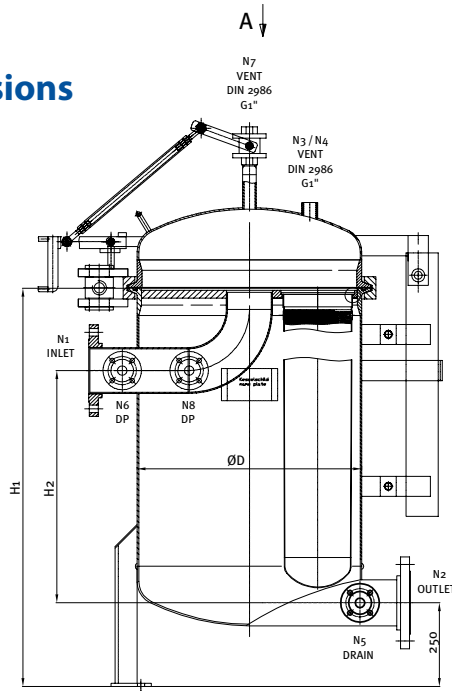

Fig. 2

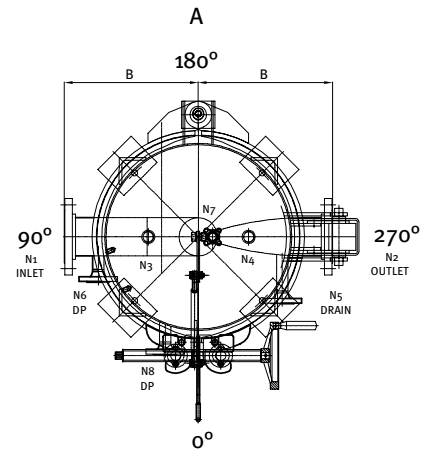

Fig. 3

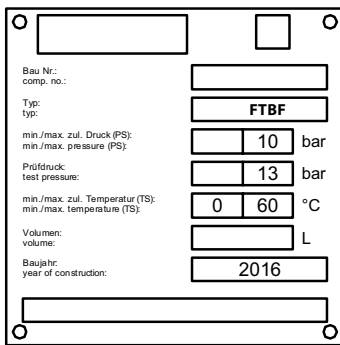

Fig. 4: Type plate example

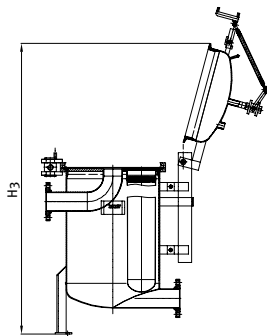

Fig. 5

MODEL	FLOW RATE (M ³ / HF)	N1 / N2 INLET / OUTLET	N3 / N4 / N7 VENTING	N5 DRAINING	N6 / N8 DP (DIFFERENTIAL PRESSURE)	ØD	H1	H2	H3	B
FTBF-M3	120	DN 80 EN 1092-1 11 PN 6-16 / 3" ANSI B 16.5 Class 150# RF *	G1" - DIN2986	DN25 PN16 - DIN EN 1092-1/11B		458	920	500	1.670	350
FTBF-M4	160	DN 100 EN 1092-1 11 PN 6-16 / 4" ANSI B 16.5 Class 150# RF *	G1" - DIN2986	DN25 PN16 - DIN EN 1092-1/11B		558	926	508	1.780	400
FTBF-M5	200	DN 125 EN 1092-1 11 PN 6-16 / 5" ANSI B 16.5 Class 150# RF *	G1" - DIN2986	DN25 PN16 - DIN EN 1092-1/11B		608	930	508	1.830	425
FTBF-M6	240	DN 150 EN 1092-1 11 PN 6-16 / 6" ANSI B 16.5 Class 150# RF *	G1" - DIN2986	DN25 PN16 - DIN EN 1092-1/11B		658	935	508	1.890	450
FTBF-M8	320	DN 200 EN 1092-1 11 PN 6-16 / 8" ANSI B 16.5 Class 150# RF *	G1" - DIN2986	DN25 PN16 - DIN EN 1092-1/11B		760	1.016	482	2.050	500
FTBF-M10	400	DN 250 EN 1092-1 11 PN 6-16 / 10" ANSI B 16.5 Class 150# RF *	G1" - DIN2986	DN25 PN16 - DIN EN 1092-1/11B		912	1.102	483	2.300	575
FTBF-M12	480	DN 300 EN 1092-1 11 PN 6-16 / 12" ANSI B 16.5 Class 150# RF *	G1" - DIN2986	DN25 PN16 - DIN EN 1092-1/11B		962	1.102	483	2.350	620

* Other flange standards possible



FTBF-M
Multi-bag filter



Fig. 6

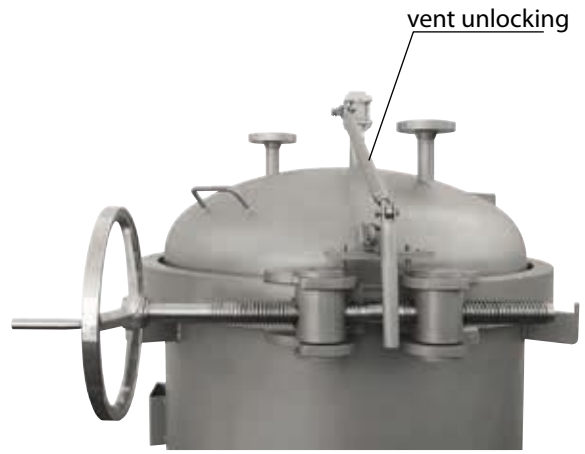

Fig. 7



Fig. 8



Fig. 9

Filter bags

For a wide number of filtration applications Fil-Tec filter bags are a simple, easy to use and economical choice.

Fil-Tec needled felt bags are mainly employed where depth filtration is required.

The three dimensional media provides good depth filtration characteristics and high solids loading versus two dimensional media.

Features

- Bags are quick and easy to change-out. Insideout flow keeps contaminants enclosed in the bag.
- Bags are silicone free (does not apply to 0.5 µm AP bag) and are produced in a silicone free environment.
- The amaFlow AP 0.5 bag has an improved selectivity because of a special coating layer on the felt.
- Materials used comply with FDA requirements for food and beverage contact.
- Filter bags and bag filter housings are usually employed as closed systems, but open or end-of-pipe applications are attractive alternatives.
- The standard amaFlow filter bags have sizes to fit into amafiltergroup baskets and housings, but will also fit into most other housings. Special sizes are available on request.
- Cost effective at lower microns versus two dimensional media (mesh).

Types

Fil-Tec needled felt bags are available as standard in polyester or polypropylene with many different micron ratings. Other materials such as nylon, viscose, PTFE, PPS and Nomex® are available on request.

Fil-Tec filter bags seal with either a Snap-Collar seal comprising of either carbon steel, stainless steel or polypropylene or with a plastic seal flange. For open systems (uses outside a filter housing) the filter bags can also be supplied without any ring (thus no integrated means of fastening) or with a pull cord only.

Surface treatment

Polypropylene is thermally treated on the outside as standard, for polyester this is available as an option. This will further minimise any possible release of fibres from the needled felt filter media. During the thermal treating process the softened fibres are bonded

together on the downstream side of the bag. Also available as an option are anti-migration covers on the felt, made either from non-woven nylon fleece.



Description

Fil-Tec needled felt filter bags are sewn as standard at the ring, have a welded longitudinal seam and are sewn at the bottom seam. Other configurations are possible depending on material. The polyester and polypropylene filter bags are equipped with handles as standard:

- S, SS, PO: Finger grips inside bag (slits in felt)
- P: 2 handles in ring (size 3, 4, 30, 65: 1 handle) An additional handle strap is optional, from the same material as needled felt.

Sealing systems

In order for bag filters to function properly, especially with smaller pore sizes, a good seal between bag and support basket is of great importance. For this reason Fil-Tec Filter has two options:

- Snap-Collar: a felt-covered metal or plastic ring which clicks neatly into the upper collar of the support basket. The felt serves as the sealing.
- Plastic-Seal: the plastic flange (with handles) which tightly fits into our standard baskets.

Multi layered and pleated felt bags

Bags with multiple layers or pleats offer advantages when removing particles which are difficult to filter and have a longer service life. For information on amaFlow multi layered or pleated felt bags please see Data Sheets 6016 and 6017.

Temperature and chemical resistance

Filter bag grade AP	AP polyester	SP polyprop.	N	TF PTFE	RT PPS	X viscose
Max. temperature °C	150*	100	100	250	170	100
Resistance to:						
inorganic acids	++	++	-	+++	+++	-
organic acids	++	+++	+	+++	+++	++
alkalines	+	++	+++	+++	+++	+
oxidising agents	++	+	-	+++	-	+
solvents	+++	++	+++	+++	+++	++
animal oils	+++	+++	+++	+++	+++	+++
vegetable oils	+++	+++	+++	+++	+++	+++
micro-organisms	+++	+++	+++	+++	+++	-

* 100 °C for polypropylene ring / flange

+++ excellent
 ++ good
 + fair
 - bad

Ordering code

	amaFlow	AP	10	P	2	S	
Material							Other options 1PK: single packed in plastic bag, together in box
AP: polyester							
SP: polypropylene							
N: nylon							
TF: PTFE							
RT: PPS							
X: viscose							
Micron rating [µm]							Additional handle HS: handle strap, from same material as needed felt (standard on size 30 and 65 for S, SS and PO ring)
AP: 0.5, 0.8, 1, 3, 5, 10, 25, 50, 75, 100, 150, 200							
SP: 0.8, 1, 3, 5, 10, 25, 50, 75, 100, 150, 200							
N: 1, 5, 10, 25, 50, 100							
TF: 1, 5, 10, 15							
RT: 1, 2.5, 5, 10, 20, 100							
X: 5, 10, 25, 50, 100							Welded / sewn: -: Standard with ring sewn, longitudinal seam welded and bottom seam sewn. For AP 0.5, all N, TF, RT, X and for all sizes 3, 4, 30 and 65: standard all sewn.
Finish							Options for AP x 0.8 and SP in size 1 and 2: AS: all sewn WE: all welded (P flange only) BW: ring sewn, longitudinal and bottom seam welded (S, SS, PO)
P: plain (not for SP)							
P/S: standard finish for SP SP (with improved outer surface: thermally treated)							
S: outside thermally treated (AP)							
B: both sides thermally treated*							
N: nylon mesh cover*							
C: nylon fleece cover*							
* available for AP (except AP 0.5) and SP							
Bag dimensions							Ring / seal S: carbon steel ring (Snap-Collar) SS: stainless steel AISI 304 ring AISI 304 (Snap-Collar) PO: polypropylene ring (Snap-Collar, AP and SP only) P: polypropylene flange (size 1, 2 ; for AP and SP only) polyethylene flange (size 3, 4, 30, 65; for AP and SP only) T: PTFE (Snap-Collar, TF only) N: no ring DS: draw string
1 size 1 (Ø 178 x 432 mm)							
2 size 2 (Ø 178 x 787 mm)							
3 size 3 (Ø 104 x 203 mm)							
4 size 4 (Ø 104 x 356 mm)							
30 size 30 (Ø 106 x 254 mm)							
65 size 65 (Ø 106 x 559 mm)							
Other dimensions are available on request							

Type approval for seawater filters made by FIL-TEC RIXEN



AMERICAN BUREAU OF SHIPPING

Customer Name	Fil-Tec Rixen GmbH	Purchase Order No.	5023-58 ; 2015-152900
Attending Office	Hamburg	Report Number	HQ2970555
First Visit Date	27-Aug-2015	Last Visit Date	27-Aug-2015

Certification Of: -2- Seawater Strainer **Quantity:** One(1)

Survey Location: Workshop

Equipment Data

Manufacturer Number(S. No.)	5023-58-BT9, 5023-58-BT10
Model Number	Type No.5023-58-BT9 & BT10
Destination Vessel (Name)	POLAR ENTERPRISE
Destination Vessel (Class Number)	06113266
Builder/Shipyards	NORTHROP GRUMMAN SHIP SYSTEMS
Builder ID / Hull No.	2501
Vendor Tag Number	5023-58
Owner Tag Number	2015-152900
Purchaser Name	Fil-Tec Rixen, Hamburg

Additional Data

ABS Stamping HQ2970555, 08 AB 15

This is to Certify that the undersigned surveyor(s) to this Bureau did, at the request of the customer, carry out the following survey and report as follows:

Traceability of materials used on this project has been verified.

All testing (pressure/load/operational/etc.) has been carried out as applicable and verified in accordance with the applicable Rules/specifications.

Testing machines are maintained in a satisfactory condition and records of their recheck or calibration dates confirmed.

For non-ABS Grades, tests and examinations as required by the specifications as listed in this report were carried out and found satisfactory.

For details of Mechanical Properties and/or Chemical Composition, refer to the mill/manufacture's records. Final markings for identification confirmed.

- Operating Pressure : 6.8 bar
- Witnessed TP 9.8 bar @ 60 minutes
- Operating Temperature : 0-50 C
- Content: 1700 l

The equipment found acceptable pending final testing during commissioning, to the satisfaction of the attending surveyor.

Surveyor(s) to The American Bureau of Shipping
Attending Surveyors

Freighting Manfred

Electronically Signed on 27-Aug-2015

Reviewed By
Kastus, Mark

Electronically Signed on 27-Aug-2015, Augsburg Station

NOTE: This report evidences that the survey reported herein was carried out in compliance with one or more of the Rules, guides, standards or other criteria of the American Bureau of Shipping and is issued solely for the use of the Bureau, its committees, its clients or other authorized entities. This Report is a representation only that the vessel, structure, item or material equipment, machinery or any other item covered by this Report has been examined for compliance with, or has met one or more of the Rules, guides, standards or other criteria of American Bureau of Shipping. The validity, applicability and interpretation of this report is governed by the Rules and standards of American Bureau of Shipping who shall remain the sole judge thereof. Nothing contained in this Report or in any notation made in the contemplation of this Report shall be deemed to relieve any designer, builder, owner, manufacturer, seller, supplier, repairer, operator or other entity of any warranty express or implied.



Fil-Tec filter housing

Series FT06

- ✓ For standard filter cartridges from 248 mm to 40"
- ✓ Manufactured entirely out of stainless steel
- ✓ Easy to service thanks to the quick release cover
- ✓ Easy to clean thanks to polished surfaces
- ✓ Simple and inexpensive design

Technical data

Maximum permissible operating pressure: 1000 kPa (10 bar)
 Maximum permissible operating temperature: 80°C

Connections

Inlet and outlet:
 Internal thread 1 1/2"

Drainage: **Ventilation:**

- Internal thread DIN 2999 - Rp 1 1/2"
- Internal thread DIN 2999 - Rp 2," (Rp 3")
- Internal thread DIN 2999 - Rp 1/2"
- Internal thread DIN 2999 - Rp 3fs"

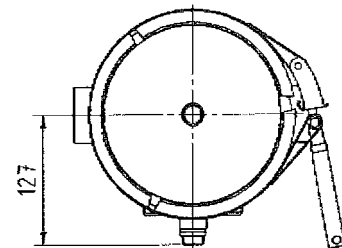
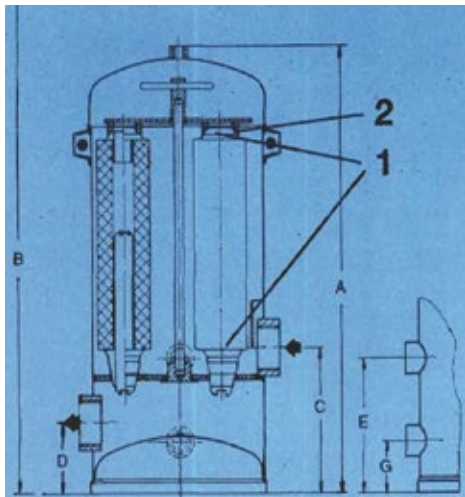
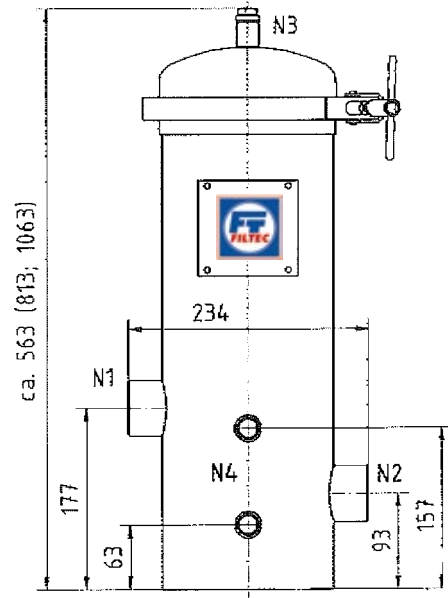

The filter cartridges are sealed by means of cutting-edge sealing caps (1) and counter-pressure springs (2).

Type:	Height	Width	Number of candles	Candle type:	Contents	Weight	Inlet/Outlet	Ventilation/Discharge
FT06-10	563	234	3	10"	9.5 l	9.5 kg	Internal thread 1 1/2"	Internal thread 3/8" Internal thread 1/2"
FT06-20	813	234	3	20"	15.0 l	12.0 kg	Internal thread 1 1/2"	Internal thread 3/8" Internal thread 1/2"
FT06-30	1063	234	3	30"	20.5 l	14.0 kg	Internal thread 1 1/2"	Internal thread 3/8" Internal thread 1/2"

FTDF-K

DUPLEX FILTER
PN 10 – 25
DN 15 – 125
ANSI 1/2" – 5"
JIS 15-125
GOST 15-125

Application areas

The FTDF duplex filter can be used in pressure and suction modes and is versatile for coarse and fine filtration. It is characterized by continuous filter operation during the cleaning possibility. The filter is compatible with the FTSF series. The filter combines the so-called housing sizes (GR) with the various nominal widths (DN) of the flange connection.

FTDF-K has a bolts and nuts lock and can also be delivered with screws and nuts as well as with a quick acting lever lock (medium-dependent - risk analysis required). Subsequent on site retrofitting is also possible.

Brief description and function

The duplex filter, cast as a component, comprises two identical single filters, connected via a cockswitching device to a filter side or can be operated in parallel. Medium to be filtered enters the filter basket from the top and flows through the insert inside out.

Dirt thus remains in the filter element.

As a special version, the filter is also available with star filters (changed inflow).

Safety instructions

Filters with lever locks are not suitable for the filtration of hazardous media (e.g. poisonous, inflammable or corrosive). In such cases, screws and nuts must be selected as lid closures. Generally, use of filter with switching valve must be checked for hazardous media (leakage rate permitted by the design). FTDF-K filters are not suitable for the filtration of gases.

Check the filter for intended operation prior to usage. Conformity assessment as per PED EN 97/23 EC.



DN 20 – DN 125 PN 10/16
 (plug switchover)
 E.g. Ductile iron



DN 20 – DN 125 PN 10/16
 (plug switchover)
 E.g. Bronze

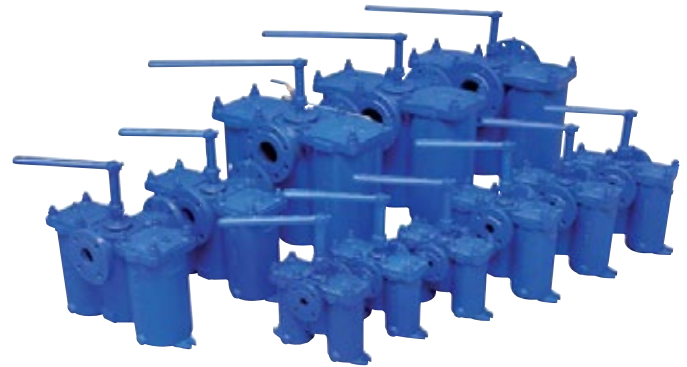

must be done for changes in operating conditions or the media (kindly contact us for the same or run a risk analysis with conformity assessment).

Commissioning

- Check whether all screws and locks have been tightened properly.
- Check the position of the switching lever (there is a covered  on the switching valve, which defines the direction of flow and/or shows "in operation" on the filter pot. The handle must be fitted accordingly).
- Venting: Venting device fitted in the housing of every single filter is open till the fluid discharges. The filter is ready-to-operate after venting the single filter.

Approvals

3.1. Certificate, DGRL / TÜV, GL, LS, DNV, ABS, TR TF / TR CU Certificates (EAC)



Cleaning/Operation

Note: Since it is a pressure vessel, it is important to ensure that the container is without pressure prior to beginning of maintenance.

1. As soon as the filter half is dirty (increasing differential pressure on the indicator or decreasing operating pressure in the system), the clean filter half is put into operation by gradual switching of the plug valve.
2. Proceed with cleaning (removal of filter element) only after opening the venting device slowly and
3. if the filter is build with a pressure equalization line, then open line for easier switching.
4. After opening the drain plug and draining the remaining fluid from the container (filter side to be cleaned):

Caution: note maximum differential pressure of the filter (standard $D_p = 1$ bar).

Cleaning

The filter side to be cleaned must be depressurized (open vent carefully after switching over to the other filter side).

1. Then lift by loosening the filter cap or the screws and nuts of the cover of the filter half to be cleaned.
2. Note cover gasket integrity during assembly, replace if necessary.

Important: Duplex filter with switching valves have a permissible leakage rate, leakage rate of the FTDF filter at delivery condition at max. design pressure (P_{design}) is approx. 20% of the contents of the vessel in approx. 30 minutes.

INFORMATION: Hence, do not leave the opened filter unattended and if required, keep an already cleaned reserve filter element ready for replacement.

Important information for switchover

For media having corrosion effect on the material of the filter, switching must be actuated regularly (2-3 times) per week.

Alternative to the standard switching valves in EN GJS5007, switching valves in bronze or standard coated with Magna Coat® are also available.

Vessel

DIN EN GJS-500-7 / (GGG-50 / ASTM 80-55-06)
alternatively annealed GJS-400-18 / (GGG 40.3)

Alternative vessel material

RG 5/10 G-CuSn5(10)ZnPb

Heating

Filters may be additionally fitted with heaters for smooth start and continuous reduction in the viscosity of the medium to be filtered.

Advantages of FTDF-K

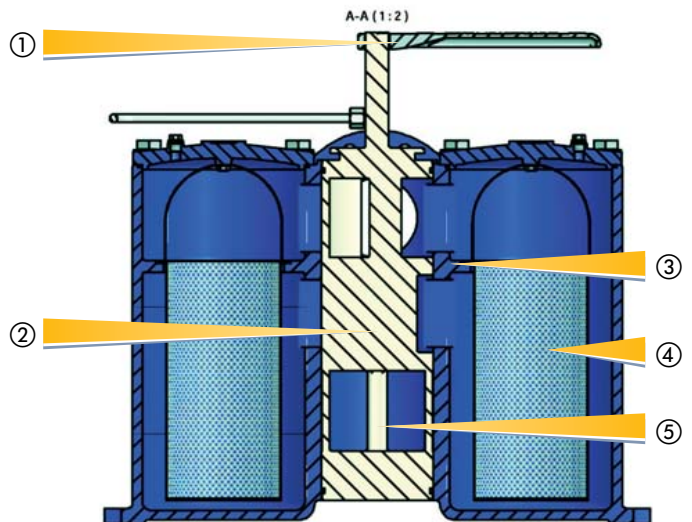

- ① Large ergonomic switching lever
- ② Smooth switching due to smoothed surface
- ③ Combination of connection flanges to housing sizes/ filter areas
- ④ Dirt remains in the basket strainer
- ⑤ Medium-resistant switching in
 - nodular cast iron
 - bronze
 - polymer coated

Technical data and dimensions 1

Flange opposite duplex filter with switching valves

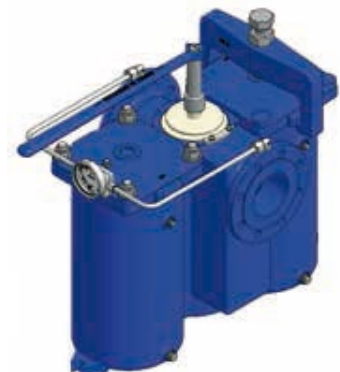
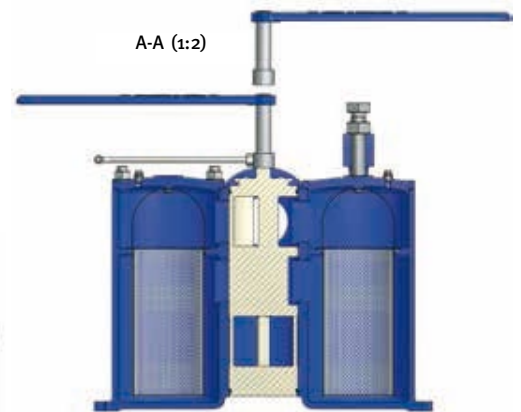
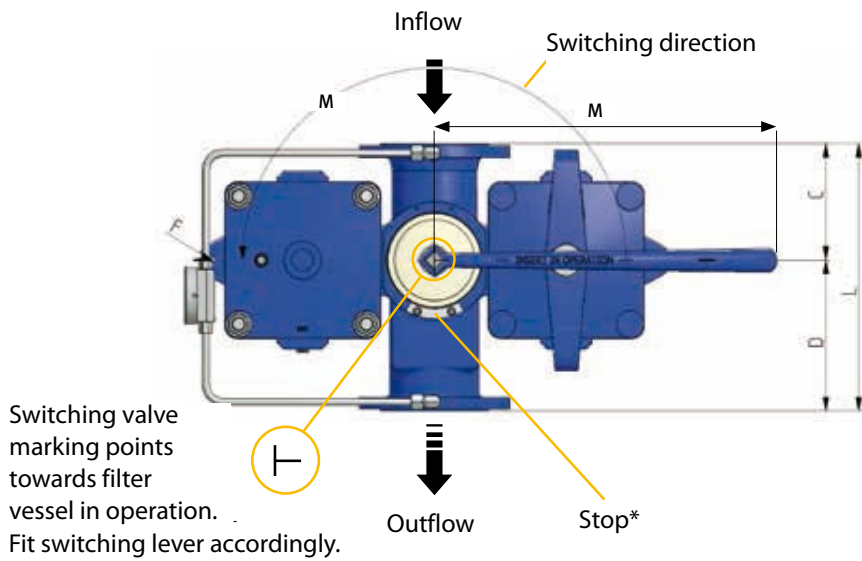
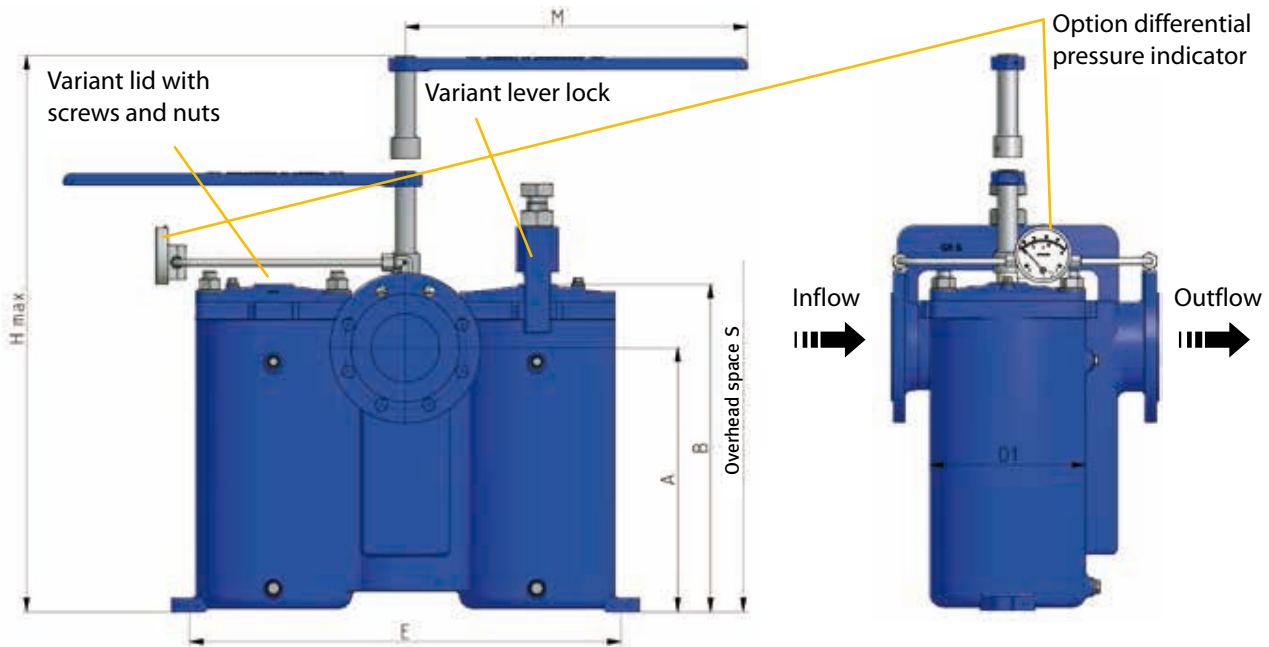

*Switching direction of the switching lever can be changed by changing the stop.

Technical data and dimensions 2

Flange opposite duplex filter with switching valves

Housing-size	Nominal diameter Flange connection	Pressure stage		ØD1	A	B	C	D	E
		Lock	Screws						
		DN							
	mm	bar	bar	mm	mm	mm	mm	mm	Range of the base mm
2	15	16	16	102	185	242	80	95	290
2	20	16	16	102	185	242	80	95	290
2	25	16	16	102	185	242	80	95	290
3	32	16	16	127	235	298	100	130	364
3	40	16	16	127	235	298	100	130	364
3	50	16	16	127	235	298	100	130	364
4	50	10	16	168	267	328	125	190	504
4	65	10	16	168	267	328	125	190	504
4	80	10	16	168	267	328	125	190	504
6	65	10	16	228	385	478	175	220	655
6	80	10	16	228	385	478	175	220	655
6	100	10	16	228	385	478	175	220	655
6	125	10	16	228	385	478	175	220	655

Housing-size	F	S	H	L	M	Flow rate	Contents	Filter area	Pleated*	Weight
	Diameter	Filter over-head space	Height	Installation length	Lever length	at 2.5 m/s		Basket strainer		
	mm	mm	mm	mm	mm	m³/h	L	cm²	cm²	kg
2	14	450	420	175	300	3	1,2	270	on request	21
2	14	450	420	175	300	3	1,2	270		22
2	14	450	420	175	300	4,5	1,2	270		22
3	14	550	480	230	300	7	3,5	440		38
3	14	550	480	230	300	12	3,5	440		38
3	14	550	480	230	300	12	3,5	440		38
4	14	650	600	315	500	18	6,5	740		69
4	14	650	600	315	500	30	6,5	740		70
6	14	900	720	395	500	18	15	1.350		175
6	14	900	720	395	500	45	15	1.350		175
6	14	900	720	395	500	70	15	1.350		175
6	14	900	720	395	500	70	15	1.350		175

* all dimension subject to modification, as built in approved Fil-Tec drawing.

Dimensions only for information – certified dimensions in approved Fil-Tec installation drawing.



Foto shows optional
- pressure equalization pipe
for easy switching

Technical data

	Standard version	Special version and/or additional features
Filter element	Basket strainer insert	Dual strainer, star strainer, wedged wire
Filter unit	25 - 1000 µm: Fabric with support plate, 1 mm onwards: Perforated plate, 1 mm onwards: Perforated plate with round hole	Filter element 25–2,000 µm, 1-10 mm
Filter cap	Stud screws and nuts	Lock
Venting device	Screw	Ball valve
Draining device	Screw	Ball valve
Connection	Flange as per EN 1092-1 11B Flange position: as against the height	ANSI, JIS, as per customer specification GOST
Material:		
Housing and lid	DIN EN GJS-500-7 / (GGG-50 / ASTM 80-55-06)	RG 5/10/G-CuSn5(10)ZnPb GGG-40.3 / EN GJS 40-18 LT
Lid gasket O-ring	NBR	FPM, EPDM, PTFE
Perforated plate/fabric	St, St/1.4401, 1.4301, 1.4301/1.4401	1.4571/-, 1.4571/1.4401, MS/-, MS/BZ
Switching cock (up to DN 100)	EN GJS-500-7 / (GGG-50 / ASTM 80-55-06) oil version EN GJS-500-7 coated cock with Magna Coat® polymer/flourpolymer (water version)	RG5 G-CuSn5ZnPb
Venting	Stainless steel screw 1/4"	Brass, ball valve, as per specification
Extras		
Additional filter	-	Magnetic filter element
Heater	-	Vapour, oil, warm water or electric heating
Zinc protection	-	for sea water filter
Differential pressure indicator	-	optical, electrical, contacts
Body/Cover Surface treatment		
internal	Anti-corrosion primer or untreated	Anticorrosion oil, epoxy resin coating, rubber coating
external	Synthetic resin coating RAL 5010	RAL as per specification
Design/Certification	Declaration of Conformity, 3.1 Material Certificates – Lloyds Register certified foundry acc. to DGRL 97/23/EC (CE)	on request

Accessory

We produce and deliver additional design and material variants on request.

We solicit your request.

Fil-Tec Differential-Pressure Indicator
Type : FT4.36.2





DN/NW 80 unit with Fil-Tec Differential-Pressure Indicator, Type : FT4.36.2



Example FTDF-V NW 100 cast iron from product range NW 100-500



Example FTDF-W NW 80 SS316 from product range NW 25-500

FTDF-V

DUPLEX FILTER
PN 10 - PN 64
DN 100-600
ANSI 4" - 24"
JIS 100-600
GOST 100-600



Application areas

The FTDF duplex filter can be used in pressure and suction modes and is versatile for coarse and fine filtration. It is characterized by continuous filter operation during the cleaning phase. The filter combines so-called housing sizes (GR) with various nominal flange connection widths (DN).

FTDF-V has a lid-combination lock and can also be delivered with screws and nuts as well as with a quick acting lever lock (medium-dependent - risk analysis required). Subsequent on-site retrofitting is also possible. A danger analysis has to be performed before start up acc. PED or applicable codes and standards.

Brief description and function

The duplex filter, comprises two identical single filters, connected via a valve-switching device to a filter side or can be operated in parallel. Medium to be filtered enters the filter basket from the top and flows through the insert inside out. Dirt thus remains in the filter element.

As a special version, the filter is also available with star filters (changed inflow).

Safety instructions

Filters with lever locks are not suitable for the filtration of hazardous media (e.g. poisonous, inflammable or corrosive). In such cases, screws and nuts must be selected as lid closures. Generally, use of filter with switching valve must be checked for hazardous media. The use of FTDF-V filters for gases requires a review by the manufacturer. Check the filter for intended operation prior to usage. Conformity assessment as per PED 97/23 EC must be done for changes in operating conditions or the media (kindly contact us for the same or run a risk analysis with conformity assessment).



DN 100 – DN 600 PN 16
(Valve switching)

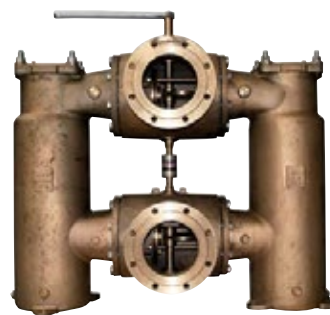

FTDF-V Bronze



FTDF-V Stainless steel

Approvals

3.1. Certificate, DGRL / TÜV, GL, LS, DNV, ABS, GOST/RTN





Commissioning

- The pressure equalization line must be opened prior to commissioning.
- Check whether all screws and locks have been tightened properly.
- Check the position of the switching lever (here is an incised  on the shaft, which defines the direction of flow and/or shows "in operation" on the filter pot. The handle must be fitted accordingly).
- Both filter chambers shall be filled simultaneously by opening the switch device slowly to avoid fast pressure equalization of the empty chamber.
- Venting: The sventing device fitted in the housing of each individual filter must be held open until fluid discharges. The filter is ready-to-operate after venting the single filter pot.
- Check whether the pressure equalization line is closed after commissioning.

Operation

Caution: Since it is a pressure vessel, it is important to ensure that the container is without pressure prior to beginning of maintenance.

1. As soon as the filter half is dirty (increasing differential pressure on the indicator or decreasing operating pressure in the system), the clean filter half is put into operation by gradual switching.
2. **IMPORTANT:** The pressure equalization line must  be opened before the switch-over. If this instruction is not followed, damage can occur  during switching.
3. Proceed with cleaning (removal of filter element) only after opening the venting device slowly and only after releasing the pressure from the chamber which shall be cleaned / pressure equalization with atmosphere pressure the cover can be removed. While removing or releasing pressure constantly check if the switch has closed the chamber and that there is no leakage. In case of leakage the process has to be stopped and the filter isolated via IN/OUT valves.
4. After opening the drain plug and draining the remaining fluid from the container (filter side to be cleaned):

Caution: note maximum differential pressure of the filter (standard $D_p = 1$ bar)

Cleaning

The filter side to be cleaned must be depressurized (open vent carefully after switching over to the other filter side).

1. Then lift by loosening the filter cap or the screws and nuts of the lid of the filter half to be cleaned.
2. Note lid gasket integrity during assembly, replace if necessary.

INFORMATION: Hence, do not leave opened filters unattended and if required, keep an already cleaned reserve filter element ready for replacement.

Important information for switchover

For media having a corrosive effect on the material of the filter, switching must be actuated regularly (2-3 times) per week. Filters are alternatively available in bronze, or in stainless steel 1.4571 or 1.4408 (SS316).

Material/housing

DIN EN GJS-500-7 / (GGG-50)

alternatively annealed GJS-400-18 / (GGG 40.3)

Alternative materials

RG 10 G-CuSn(10)5

1.4571 stainless steel

Steel for example PGH 284, St 37.5 and others acc. ASTM

Heater

Filters may be additionally fitted with heaters for smooth start and continuous reduction in the viscosity of the medium to be filtered.

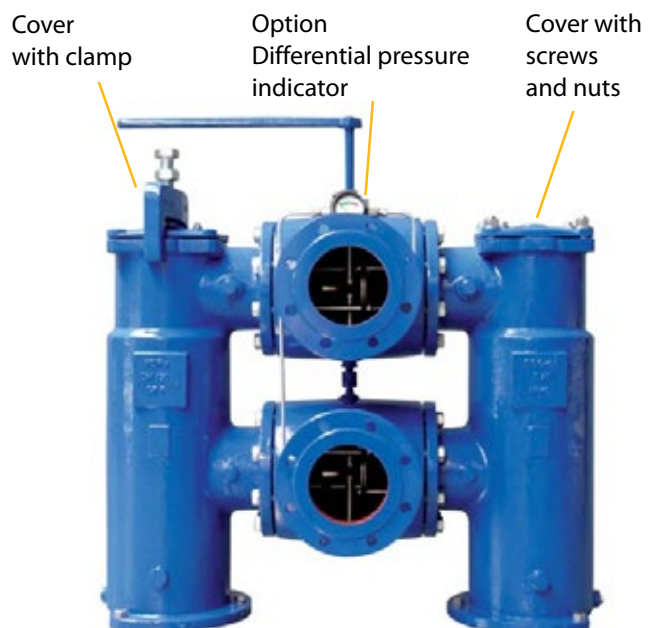

Technical data and dimensions¹⁾

Valve duplex filter (cast housing model)

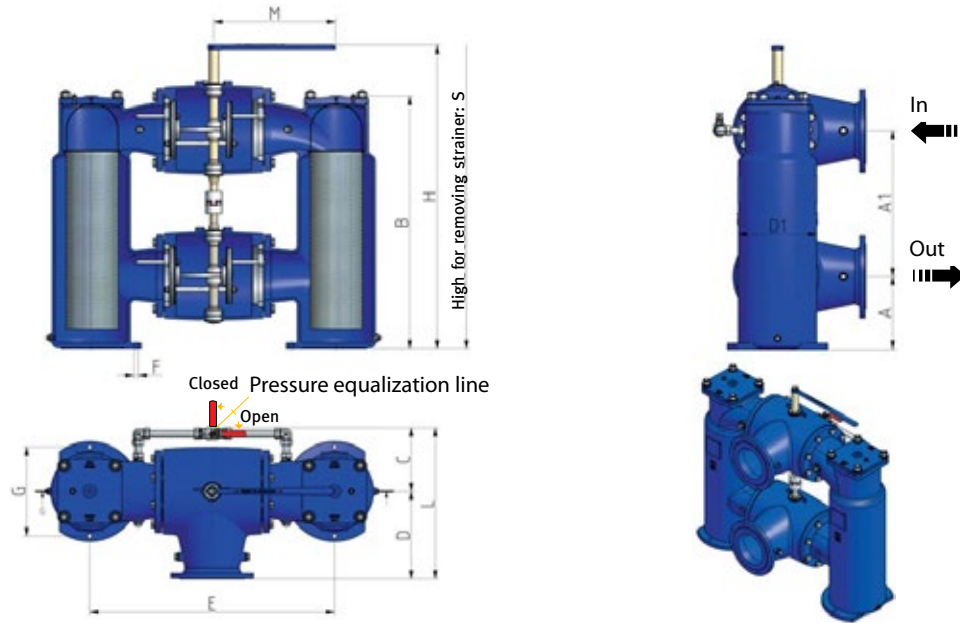

Housing size	Nominal flange connection width	Pressure stage		Ø D1	A	A1	B	C	D	G
	DN	Lock	Screws							
	mm	bar	bar							
7	100	10	16	262	265	435	840	260	250	290
7	125	10	16	262	265	435	840	260	250	290
7	150	10	16	262	265	435	840	260	250	290
8	150	10	16	325	300	600	1.037	268	362	375
8	200	10	16	325	300	600	1.037	268	362	375
8	250	10	16	325	300	600	1.037	268	362	375
10	300	–	16	469	400	700	1.359	400	410	560
10	350	–	16	469	400	700	1.359	400	410	560
11	400-600	Size on request								

Housing size	F	S	H		L	M	Flow rate	Contents	Filter area ²⁾	Weight	
	Diameter	Filter removal height	Height mm		Overall length	Lever length	for 2.5 m/s		Basket strainer		Ring strainer
	mm	mm	Lock	Screws	mm	mm	m ³ /h		l		cm ³
7	18	1.550	1.150	1.000	510	500	70	105	3.030	4.370	380
7	18	1.550	1.150	1.000	510	500	110	105	3.030	4.370	382
7	18	1.550	1.150	1.000	510	500	160	105	3.030	4.370	388
8	18	2.000	1.400	1.250	642	500	160	205	4.830	5.780	550
8	18	2.000	1.400	1.250	642	500	280	205	4.830	5.780	555
8	18	2.000	1.400	1.250	642	500	440	205	4.830	5.780	562
10	23	2.650	–	1.500	815	930	635	225	7.200	8.920	1.150
10	23	2.650	–	1.500	815	930	635	225	7.200	8.920	1.150
11	Size on request										

all dimension subject to modification, as built in approved Fil-Tec drawing.

Dimensions only for information – certified dimensions in approved Fil-Tec installation drawing.

1) dimensions for welded filters differ, 2) modification possible by means of larger filter pots



Technical data

	Standard version	Special version and/or additional features
Filter element	Basket strainer insert	Dual strainer, star strainer, sleeve strainer
Filter unit	25 - 1.000 µm: Fabric with support plate, 1 mm onwards: Perforated plate, 1 mm onwards: Perforated plate with round hole	Filter element 25 - 2,000 µm, 1 - 10 mm
Filter cap	Stud screws and nuts	Lock
Venting device	Screw	Ball valve
Draining device	Screw	Ball valve
Connection	Flange as per EN 1092-1 11B Flange position: as against the height	ANSI, JIS, as per customer specification, GOST
Materials:		
Housing and lid	DIN EN GJS-500-7 / (GGG-50 / ASTM 80-55-06)	RG 5/10/G-CuSn(10)5ZnPb GGG-40.3 / EN GJS 40-18 LT 1.4571 / 316Ti steel 1.4404 / 316L steel
Lid gasket O-ring	NBR	FPM, EPDM, PTFE
Perforated plate/fabric	St, St/1.4401, 1.4301, 1.4301/1.4401	1.4571/-, 1.4571/1.4401, MS/-, MS/BZ
Venting	Stainless steel screw 1/4"	Brass, ball valve, as per specification
Extras		
Additional filter	-	Magnetic filter element
Heater	-	Steam, oil, hot water or electric heating
Zinc protection	-	for sea water filter
Differential pressure indicator	-	optical, electrical, contacts
Body/Cover Surface treatment		
internal:	Anti-corrosion primer or untreated	Anticorrosion oil, epoxy resin coating, rubber coating
external:	Synthetic resin coating RAL 5010	Paint as per specification
Design/Certification	Declaration of Conformity, 3.1 Material Certificates – Lloyds Register certified foundry acc. to DGRL 97/23/EC (CE)	on request

Accessories

We produce and deliver additional design and material variants on request.

We solicit your request.



PN 64 / 6"



PN 10 / 20"

FTDWF

Ball Cock Change-Over Filter With Armature DN 15 – DN 150, Steel, Stainless Steel PN 16 – PN 64

Areas of application

The FTDWF change-over filter consists of two FTWF series filters with intermediate-positioned ball cock change-over. It is a filter for liquid, gaseous, or pasty media that offers versatile implementation. It is characterized by high performance, low spatial requirements, as well as fast and easy cleaning. Inlet and outlet flange can be positioned as desired.

Brief description

In the standard version the filter consists of two welded steel vessels with covers that are fastened via screws and nuts. Alternatively the filter can be equipped with a strainer, ringer strainer insert or cartridges, or bag filters.

Installation

The filter is installed in pipelines via flanges. Ensure that the standard version filter is installed vertically without additional mechanical stress, tension-free. The medium must flow in the direction specified on the vessel. Incorrect installation can cause malfunctions and damage to the filter.

Commissioning/operating instructions

1. Open the vent until liquid escapes.
2. Close vent.
3. Filter is ready for operation.
4. The lever points toward the filter pot that is in operation.

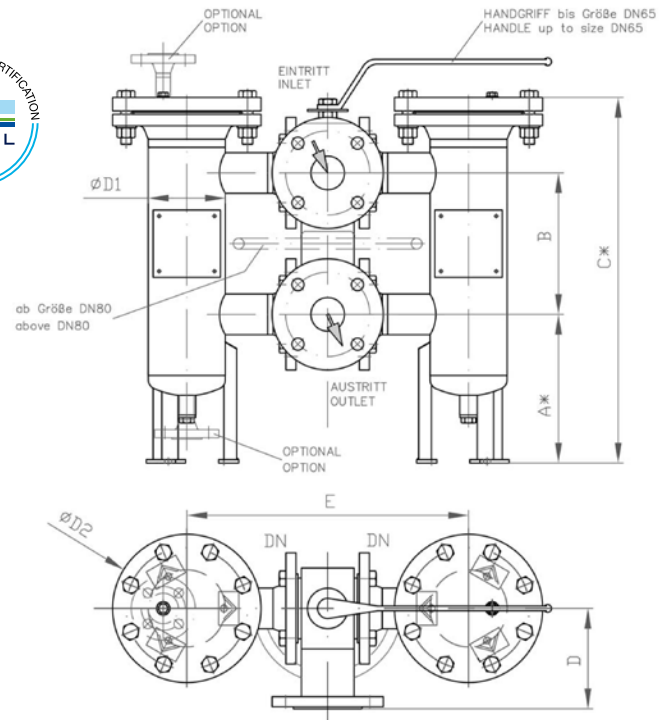

	Materials (standard version)	
Vessel	St. 35.8/P265 GH; 1.4541, 1.4571, Hastelloy, special materials plastic PE, PP, PVDF, GFK/FRP	
Filter medium	Perforated plate with stainless steel mesh, cartridges, bags	
Nominal diameter DN	Design pressure PH (standard - higher PN on request)	
15 – 50	25 (64)	16 Filter opening with retainer
65 – 100	16 (64)	10 Filter opening with retainer
125 – 300	16 (64)	16 Snap closings and cover pivot fixtures
300 – 1.000	On request filter opening with screws and nuts	Medium-dependent snap closings and cover pivot fixtures

On request approval in accordance with DGRL 97/23 EG (CE), approval in accordance with module G through TCV, GL, DHV, IRTN or GOST certificates possible.

Nominal diameter DN	PN**	ØD1	A	B	C	D	E	ØD2	Contents approx.	Flow rate	Filter surface	Weight approx.
mm	bar	mm	mm	mm	mm	mm	mm	mm	dm³	m³/h	cm²	kg
15	16	114	256	155	508	94	380	220	8	5	500	25
20	16	114	256	155	508	94	380	220	8	5	500	25
25	16	114	256	155	508	94	380	200	8	5	500	25
40	16	114	220	210	542	149	418	220	11	18	890	45
50	16	114	220	210	542	149	418	220	11	18	890	45
65	16	168	360	300	841	155	575	285	40	45	2.100	120
80	16	219	360	300	841	155	575	340	40	45	2.100	120
100	16	219	430	345	951	175	600	340	48	72	2.450	130
125	16	273	615	435	1328	240	726	405	118	162	4.300	230
150	16	273	625	435	1328	240	726	405	118	162	4.300	230

Sizes DN 200 - DN 800 on request

* variable ** to PN 64



Cleaning

Attention: Since in this case a pressure vessel is involved, strictly ensure that the vessel is depressurized before starting maintenance tasks. Comply with the safety and accident prevention guidelines required for the medium.

1. Take the filter that will be cleaned out of service by throwing over the lever - the lever will be pointing to the filter that is in operation. Depressurize the filter via the vent device or drain.
2. Loosen the vessel opening and take off the cover.
3. Empty the filter via the drain to a level that is at least below the strainer support.
4. Pull the sieve insert upward and out of the filter vessel. The strainer can now be cleaned by blowing it out or blasting it with compressed air, steam, or water. If necessary the strainer must be soaked and cleaned in a suitable cleaning agent. In some circumstances optimum cleaning is achieved via ultrasound. For all cleaning methods ensure that the filter mesh is not damaged.
5. When assembling the filter check the cover seal for wear, replace it if necessary.
6. Vent and close drain.

Technical data

	Standard version	Special version or supplemental equipment	
Filter insert	Strainer insert	Ring strainer insert double strainer	Double strainers, pleated strainer insert, cartridges, bags
Degree of filtration	10 - 1000 µm; > 1 mm: perforated plate with round perforation		
Filter opening	Through screws with nuts, (Fig. 1)	Snap closings	
Vent	Screw	Ball cock	
Drain	Screw	Ball cock	
Connection	Height-offset according to the design pressure of the filter inlet and outlet	As specified by customer	
Materials:			
Vessel and cover	St 35.8, P 265 GH, 1.4541, 1.4571	Special materials	
Filter opening	In accordance with the vessel material	-	
Cover seal	Asbestos-free flat seal	O-Ring: NBR, FPM, EPDM, MPO, PTFE	
Perforated plate/mesh	St, St/1.4401, 1.4301, 1.4301/1.4401	1.4571/1.4401, MS/Bz, Hastelloy C 4, various plastics	
Attachment parts	VA		
Supplemental filter	-	Magnetic filter insert	
Heater	-	Steam, hot water or electrical heater	
Differential pressure indicator	-	Optical, electrical	
Surface treatment interior:*			
Vessel steel	Preservation oil	Corrosion protection lacquer, epoxy resin, E-CTFE	
Vessel stainless steel	Glass-shot blasted	Pickled and passivated, electro-polished	
Vessel plastic PP, PE, PVDF, GFK/FRP			
Surface treatment exterior:			
Vessel steel	Synthetic resin lacquer, RAL 5010 blue	Rubberized, epoxy-coated, as well as customer-specific	
Vessel stainless steel	Glass-shot blasted	Pickled and passivated	

*Selector switch cannot be coated.

We manufacture and deliver additional design and material variants on customer request. **We request your enquiry.**

FTDFDN65

Fil-Tec Duplex Filter with flange connection DN 32-80 available with heating

Application areas

The FTDF duplex filter can be used in pressure and suction modes and is versatile for coarse and fine filtration. It is characterized by continuous filter operation during the cleaning phase. The filter is compatible with the FTSF series. The filter combines the so-called housing sizes (GR) with the various nominal widths (DN) of the flange connection. FTDFDN has a bolt and nut lock and can also additionally be delivered with filter cover safety device and differential pressure indicator.

Brief description and function

The duplex filter, cast as a component, comprises two identical single filters, connected via a cock switching device to a filter side or can be operated in parallel. Medium to be filtered enters the filter from the top or the bottom flange (depending on type of element : multimantle, star,- or candle sieve insert from bottom, Basket-element from top) and flows through the insert inside or outside in/ out. Dirt thus remains in the filter element, basket type or is collected on the surface of filterelement (Multimantle,- Star,- and candle-sieve-element).

Safety instructions

Generally, use of filter with switching valve must be checked for hazardous media (leakage rate permitted by the design). FTDF filters are not suitable for the filtration of gases. Check the filter for intended operation prior to usage. Conformity assessment as per PED EN 97/23 EC must be done for changes in operating conditions or the media (kindly contact us for the same or run a risk analysis with conformity assessment).

Technical Characteristics

- Filter housing of ductile iron; internally nickel lined for water application
- Change-over valve of cast iron; water filters rubber-lined
- Optionally star-pleated, candle,- or basket filter element, star-pleated element also available as disposable filter element
- Filter fineness: 10 microns to 5 mm (absolute Meshsize)
- Operating pressure ductile iron up to 25 bars

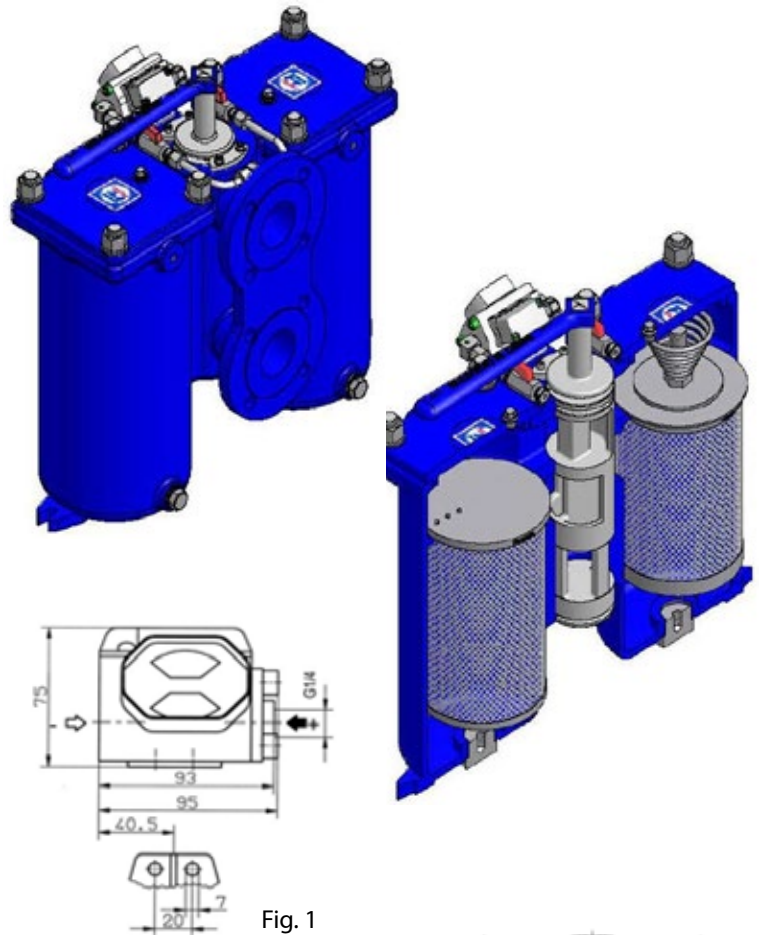

Fig. 1

Fig. 2

Optional Accessories

Differential pressure indicator type 4.36 (fig.1) can be supplied fitted at factory. The filter elements can be fitted with magnetic bars. Heating available. Cover safety device (fig.2)

Cleaning

- Switch change-over valve to clean filter chamber
- Release pressure in the contaminated filter chamber by means of venting screw
- Lift the cover of the contaminated filter chamber
- Remove filter element
- Soak filter element in cleaning fluid, e.g. Fil-Tec FT 31, and clean with compressed air For details see operating instructions manual "maintenance and servicing".
- Always drain filter chamber and clean it (in case of multimantle,- pleated and candle inserts, the chamber is dirtside.

Technical data

Filter element	Standard	Options
Filter unit	Multimantle element	Basket,-Ring,-Pleated,-Paper or Candle-insert
Filter cover	Filter-elements 25 µm – 1000 µm	Filter-elements 25 µm – 1000 µm
Venting device	Stud screws with nuts	Lock
Draining device	Screw	Globe valve G1/4"
Connection	Screw	Globe valve G1/2"
Material	Flange DIN 2635 B	ANSI/JIS , customer specifications
Housing and Cover	-	RG5/10/G-CuSn5ZnPb/ GGG-40-3/EN GJS 40-18 LT FPM,FPM-GF, EPDM
Cover gasket	DIN EN GJS-500-7 (GGG50)	Globe valve steel, brass
Venting	O-Ring : NBR	Magnetic insert
Additional Filter	Screw Steel	Steam, oil electrical heating
Heating	-	Sea water applications
Zinc protection	-	Optical, electrical (Fig. 1)
Diff. Press.Indicator	-	Cover safety device (Fig.2) Fuel oil application
Safety device	-	Epoxy resin coating, rubber coating
Surface treatment	-	RAL as per specification
Internal	Anti corrosion primer, untreated	3.1 Certificate,DGRL/TÜV,GL,DNV,ABS
External	Synthetic resin coating RAL 5010	
Approvals	-	

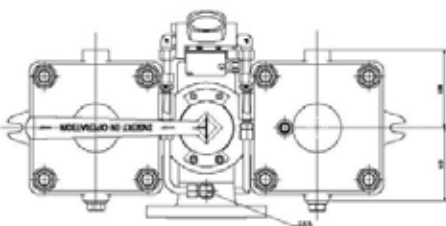
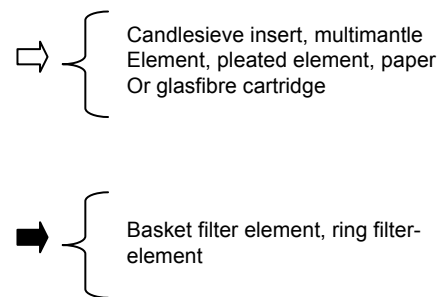
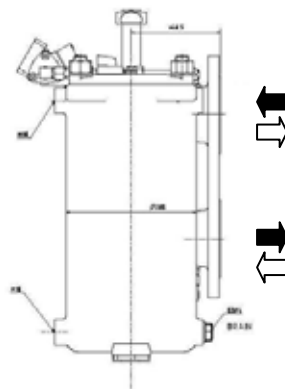
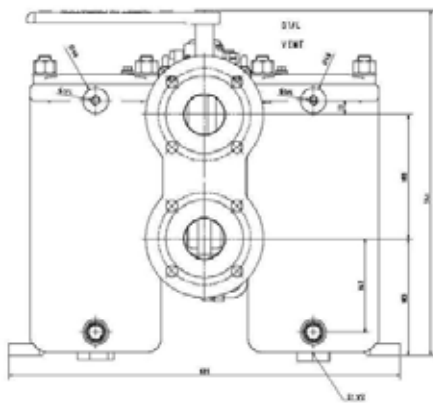

DN	Name	Filterelements
32	FTDN32	Basket,-Multimantle,-Ring,-Pleated-element
40	FTDN40	Basket,-Multimantle,-Ring,-Candle,-Pleated-element
50	FTDN50	Basket,-Multimantle,-Ring,-Candle,-Pleated-element
65	FTDN65	Basket,-Multimantle,-Ring,-Candle,-Pleated-element
80	FTDN80	Basket,-Multimantle,-Ring,-Candle,-Pleated-element

FTAF Bernoulli

Self-Cleaning Automatic Filter

No Contact Cleaning

No Process Interruption

DN 40 – DN 1000 | PN 2,5 – PN 25

EN / ANSI / JIS / GOST

Applications

The self-cleaning automatic FTAF Bernoulli filter is a versatile self-cleaning, virtually maintenance-free filter for removal of particulate contaminants from highly polluted waters as well as process fluids e.g. from natural water sources (sea water, river water) and heating or cooling circuits and processes. It operates at a working pressure as low as 0.3 bar and is characterized by extremely low pressure loss of 0.09, for example, at a high flow rate, simple, robust design, with high performance, low weight, and space saving.

- from a working pressure of 0.3 bar
- the filter can be integrated in the pipe system in any installation position
- filtration stage ≥ 160 microns (100 μ possible) - 10 mm

Brief description of operation

A specially shaped flushing disk gives rise to an increase in speed between the disk and strainer in the flushing process. The resulting local pressure drop causes internal evacuation of the contaminant particles from the strainer insert. Solid components are flushed out via the simultaneously opened flush valve. The filter is equipped with a differential pressure monitoring system that automatically triggers the flushing process before any blockages in the filter strainer cause significant flow reductions. The flushing process can also take place after a predetermined time.

- Filtrate flow is not interrupted in this process; the flushing volumes are low.
- The pressure drop in the system is minimal.

Installation

Operating instructions: The comprehensive instructions accompanying the filter must be followed!

The filter is installed in pipes using flanges. Ensure that the standard version of the filter is installed vertically or horizontally in a mechanically stress-free manner without additional loads. The medium must flow in the direction specified on the housing. Incorrect installation can cause filter malfunctions. If the contaminant drain pipe is laid with an ascending gradient ensure that the inlet pressure of the filter is at least a 0.3 bar higher than the counter pressure in the contaminant

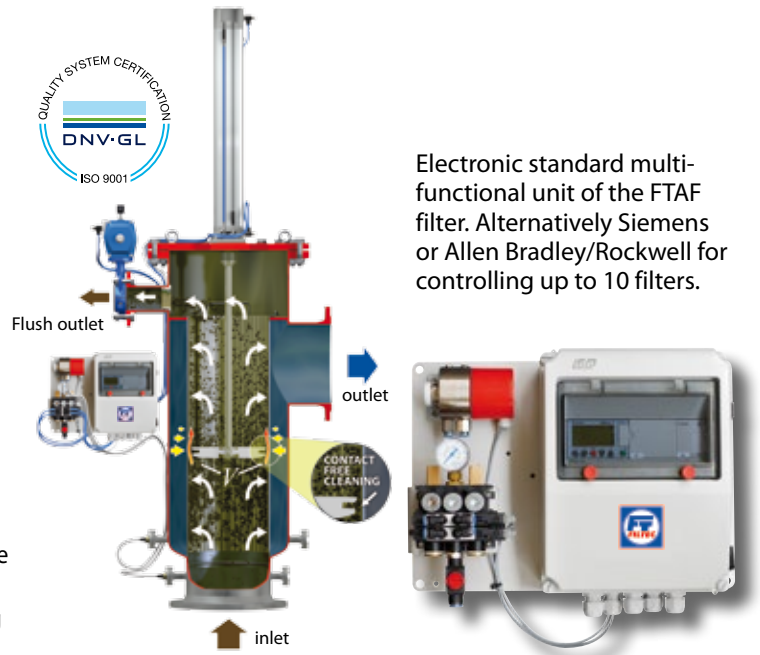

Electronic standard multi-functional unit of the FTAF filter. Alternatively Siemens or Allen Bradley/Rockwell for controlling up to 10 filters.

Functional description of the cleaning process

The contaminated medium flows into the filter through the flange marked inlet. The contaminated medium flows through the filter insert from the inside to the outside and exits out of the flange marked outlet as cleaned medium. The flushing phase of the filter is either activated when the set differential pressure is attained, or the flushing phase is activated after a set time interval. The flush-ing valve opens and larger contaminant particles are flushed out with the continuously flowing medium stream due to a pressure gradient. Subsequently the piston usually performs two strokes in the filter strainers, thereby increasing the speed between the piston and strainer wall. The contaminants are sucked off due to the resultant local pressure drop. The flushing time can be set by the controller according to the operating conditions, and flushing frequency depends on the level of contamination in the medium.

Approvals

3.1. Certificate, DGRL / TÜV, Mudul G, GL, LS, DNV, ABS, TR TF / TR CU Certificates (EAC), ASME, U-STAMP, CE



drain pipe (pay attention to the loss through friction in pipes). Before using with a medium other than the medium specified in the design, or for different operating data, the resistance of the materials of the parts and seals touched by the pressure-bearing membrane to the medium to be filtered must be checked by the customer; it may be necessary to consult with the manufacturer and to execute a conformity evaluation in accordance with PED EN 97 / 23 EC (if there is a CE-mark requirement).



Technical data

	Standard	Special versions
Filter insert/filtration degree	0.2–10 mm	additional on request e.g. 0.1 mm
Filter cover	Cover with hex bolts + nuts	-
Venting device	-	On request
Drain unit	-	On request
Connections	EN 1092-1 PN 10/16	As specified by the customer (e.g. ANSI, JIS)
Materials		
Housing		
Plastic	GRP / FRP (polyester-based fiber-reinforced plastic)	Cast Iron (rubberlined)
Stainless steel	1.4571, steel	Steel (rubberlined), special alloy steels
Cast Iron	GGG50 / EN-GJS-500-7 / ASTM-80-55-06	
Seals	NBR	On request
Perforated plate/slotted hole strainer	1.4571/1.4401	Titan, Hastelloy, Monel, Super Duplex, Uranus
Flushing disk	POM / GRP	-
Piston rod	1.4404	Super Duplex 1.4410/1.4501
Differential pressure switch	Ms chem. nickel-plated (Membrane)	Hastelloy, Monell (Membrane)
Version		
Differential pressure switch	Electrical with 1st contact for start of cleaning, protective class IP65	Protection rating in Ex-conformant version (ATEX), Transmitter 4-20 mA, HART protocol
Control	Multi-function unit mounted (Crouzet Millenium III) / delivered separately	Allen Bradley/Rockwell, Siemens, Eexd, Explosion-protected (ATEX),
	230 V / 50 Hz	On request
	Protective class IP64	Protection class in Ex version
Cylinder	Pneumatically activated	Electrical (depending on nominal diameter) (ATEX)
Required compressed air	6 bar	3.5 bar (Maximator), slanted seat, ball valve
Contaminant outlet valve fitting	Butterfly valve	
Surface treatment, internal		
Steel housing / Cast Iron	Corrosion protection oil / Chemonit 33 (rubberlined)	Chemonit 31 (rubberlined) Corrocoat, Polyglass
Stainless steel housing	Glass bead blasting or blasted	Pickled and passivated
GRP / FRP housing	Chemical-resistant vinylester liner	Corrocoat, Polyglass
Surface treatment, external		
Steel housing / Cast Iron	Epoxy in RAL 5010 blue	Customer specification
Stainless steel housing	Glass bead blasting or blasted	-
Housing GRP / FRP	GRP outer color or through-colored in RAL 5015 blue	Customer specification Polyurethane paint
Range of application of the materials according to temperature		
Steel / stainless steel housing / Cast Iron	Temperature limits: In accordance with PED or AD2000 legislation -29°C to 95°C	Special version: +120°C
GRP housing	Temperature limits: -70°C to +60°C	Special version: +120°C
Design/Certification	Declaration of Conformity, 3.1 Material Certificates – Lloyds Register certified foundry acc. to DGRL 97/23/EC for cast iron (GGG50/ EN-GJS-500-7/ASTM 80-55-06)	ASME-Code, ATEX, PED, NORSOK, DOSH, MOM, GOST, RTN

Technical data and dimensions

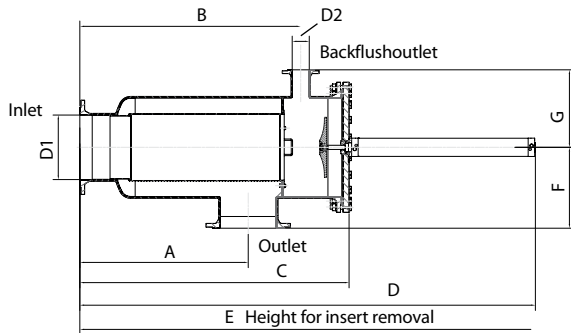

Flanges in accordance with EN 1092-1 PN 10–16 or ANSI 16.5 150 lbs

Filter dimensioning chart / Pressure loss diagram

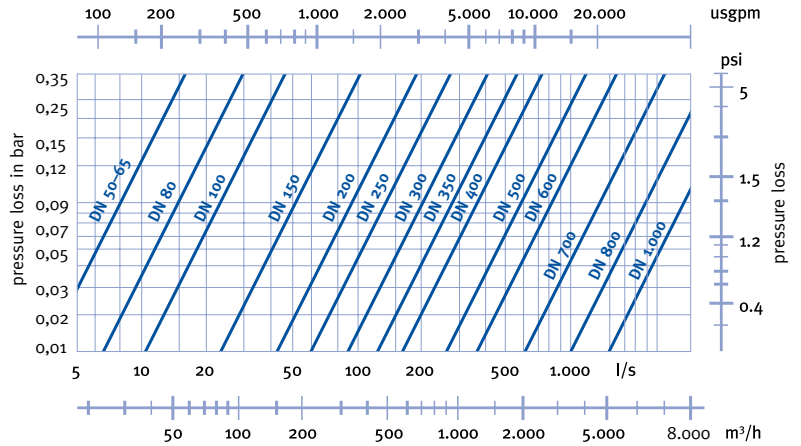

Dimension example (0.2 mm filtration degree) / selection chart at 500 m³/h, the use of a DN 250 or DN 300 is recommended at 200 µm

Material	D1	D2	A	B	C	D	E	F	G	Weight *	Flow rate ***	Example flushing volume/backflush (adjustable)
	DN	DN	mm	mm	mm	mm	mm	mm	mm	ca. kg	m³/h	m³
VA/steel **	50	25	310	385	520	1020	1100	200	135	25	8–45	0.04
	65	25	310	385	520	1020	1100	200	135	30	8–45	0.04
	80	40	405	510	620	1100	1200	235	190	35	15–80	0.06
	100	40	430	480	680	1305	1400	240	240	40	40–120	0.09
	150	40	490	680	810	1450	1550	260	255	80	50–300	0.2
	200	80	590	790	1010	1950	2050	290	280	110	100–500	0.54
	250	100	740	980	1250	2180	2280	345	330	165	160–800	1.2
	300	100	890	1155	1440	2510	2610	375	385	200	200–1100	2.2
	350	100	950	1260	1481	2467	2500	410	410	300	300–1500	2.6
	400	100	1010	1325	1535	3010	3100	485	465	450	400–2000	3.5
	500	150	1590	2205	2350	3800	3900	695	555	1600	800–3000	5.5
	600	200	1540	3055	3490	4650	4750	900	805	2300	1200–4000	9.5
700	200	2650	3255	3750	5650	5750	1200	1100	2800	1500–5000	12.5	
800	200	2550	3300	4195	6660	7000	1060	940	3200	2500–8000	14.5	
1000	250	3100	3990	5100	7000	7700	1360	1140	1800	5000–9000	15.0	
GRP	40/50	25	400	540	650	1200	1300	160	160	15	8–45	0.04
	65	25	400	540	650	1200	1300	160	160	17	8–45	0.04
	80	40	440	600	720	1300	1400	190	175	20	20–90	0.06
	100	40	460	640	800	1370	1450	220	200	25	40–120	0.09
	150	50	500	720	890	1680	1750	250	240	30	70–300	0.2
	200	80	600	870	1130	2000	2100	325	300	60	150–500	0.54
	250	100	660	1000	1290	2300	2400	370	330	90	200–700	1.2
	300	100	900	1280	1600	2800	2900	430	390	140	300–1000	2.2
	350	100	1000	1430	1810	3058	3170	500	450	205	300–1500	2.6
	400	100	1220	1670	2100	3600	3700	550	500	220	500–1800	3.5
	500	150	1680	2220	2700	4300	4400	650	580	550	800–2500	5.5
	600	200	1950	2570	3120	4500	4600	780	700	750	1200–4000	9.5
	700	200	2300	2990	3650	4750	4850	920	820	1000	1500–5000	12.5
	800	200	2550	3300	4100	6660	7000	1060	940	1400	2500–6500	14.5
	1000	250	3100	3990	5100	7000	7700	1360	1140	1800	5000–9000	15.0



Material	D1	D2	A	B	C	D	E	F	G	Weight *	Flow rate ***	Example flushing volume/backflush (adjustable)
	DN	DN	mm	mm	mm	mm	mm	mm	mm	ca. kg	m ³ /h	m ³
Cast Iron (EN-GJS-500-7 / GGG-50 / ASTM 80-55-06)	80	40	30	580	730	1210	1300	240	240	60	15-80	0.06
	100	40	430	580	730	1210	1300	240	240	60	40-120	0.09
	150	40	490	690	850	1440	1600	260	240	00	50-300	0.2
	200	80	620	810	1000	1670	1780	300	280	270	100-500	0.54
	250	100	890	1250	1460	2420	2540	380	450	520	160-800	1.2
	300	100	890	1250	1460	2420	2540	380	450	520	200-1100	2.2
	350	100	1010	1325	1670	2730	900	485	465	650	300-1500	2.6
	400	100	1010	1325	1670	2730	2900	485	465	650	400-2000	3.5

*Dependent on pressure phase, **Rubberlined on request, ***Dependent on filtration degree



24" / DN 600 FTAF Filter
Bioethanol plant



24" / DN 600 FTAF Filter
seawater cooling



3 x 16" / DN 400 FTAF Filter
desalinisation



14" / DN 350 Filter seawater cooling for
use in Ex Zone 1



200 JIS / DN 200 ship seawater cooling
for use in Ex Zone 1



300 JIS / DN 300 ship seawater cooling
for use in Ex Zone 1

FTAF-S Bernoulli

Self-Cleaning Automatic Filter
No Contact Cleaning
No Process Interruption
DN 300–1000 | PN 2,5–10
EN / ANSI / JIS / GOST



Applications

The self-cleaning automatic FTAF-S Bernoulli filter is a versatile self-cleaning, virtually maintenance-free filter for removal of particulate contaminants from highly polluted waters as well as process fluids e.g. from natural water sources (sea water, river water) and heating or cooling circuits and processes. It operates at a working pressure as low as 0.3 bar and is characterized by extremely low pressure loss of 0.09, for example, at a high flow rate, simple, robust design, with high performance, low weight, and space saving.

- from a working pressure of 0.3 bar
- the filter can be integrated in the pipe system in any installation position
- filtration stage ≥ 150 microns (100 μ possible) – 10 mm

Brief description of operation

A specially shaped flushing disk gives rise to an increase in speed between the disk and strainer in the flushing process. The resulting local pressure drop causes internal evacuation of the contaminant particles from the strainer insert. Solid components are flushed out via the simultaneously opened flush valve. The filter is equipped with a differential pressure monitoring system that automatically triggers the flushing process before any blockages in the filter strainer cause significant flow reductions. The flushing process can also take place after a predetermined time.

- Filtrate flow is not interrupted in this process; the flushing volumes are low.
- The pressure drop in the system is minimal.

Functional description of the cleaning process

The contaminated medium flows into the filter through the flange marked inlet. The contaminated medium flows through the filter insert from the inside to the outside and exits out of the flange marked outlet as cleaned medium. The flushing phase of the filter is either activated when the set differential pressure is attained, or the flushing phase is

activated after a set time interval. The flushing valve opens and larger contaminant particles are flushed out with the continuously flowing medium stream due to a pressure gradient. Subsequently the piston usually performs two strokes in the filter strainers, thereby increasing the speed between the piston and strainer wall. The contaminants are sucked off due to the resultant local pressure drop. The flushing time can be set by the controller according to the operating conditions, and flushing frequency depends on the level of contamination in the medium.

Approvals

3.1. Certificate, DGRL / TÜV, Mudul G, GL, LS, DNV, ABS, TR TF / TR CU Certificates (EAC), ASME, U-STAMP, CE



Installation

Operating instructions: The comprehensive instructions accompanying the filter must be followed!

The filter is installed in pipes using flanges. Ensure that the standard version of the filter is installed vertically or horizontally in a mechanically stress-free manner without additional loads. The medium must flow in the direction specified on the housing. Incorrect installation can cause filter malfunctions. If the contaminant drain pipe is laid with an ascending gradient ensure that the inlet pressure of the filter is at least a 0.3 bar higher than the counter pressure in the contaminant drain pipe (pay attention to the loss through friction in pipes). Before using with a medium other than the medium specified in the design, or for different operating data, the resistance of the materials of the parts and seals touched by the pressure-bearing membrane to the medium to be filtered must be checked by the customer; it may be necessary to consult with the manufacturer and to execute a conformity evaluation in accordance with PED EN 97 / 23 EC (if there is a CE-mark requirement).



Technical data

	Standard	Special versions
Filter insert/filtration degree	0.2–5 mm	additional on request e.g. 0.1 mm
Filter cover	Cover with hex bolts + nuts	-
Venting device	-	On request
Drain unit	-	On request
Connections	EN 1092-1 PN 10/16	As specified by the customer (e.g. ANSI, JIS)
Materials		
Housing		
Plastic	GRP / FRP (polyester-based fiber-reinforced plastic)	Cast Iron (rubberlined)
Stainless steel	1.4571, steel	Steel (rubberlined), special alloy steels
Cast Iron	GGG50 / EN-GJS-500-7 / ASTM-80-55-06	
Seals	NBR	On request
Perforated plate/slotted hole strainer	1.4571/1.4401	Titan, Hastelloy, Monel, Super Duplex, Uranus
Flushing disk	POM / GRP	-
Piston rod	1.4404	Super Duplex 1.4410/1.4501
Differential pressure switch	Ms chem. nickel-plated (Membrane)	Hastelloy, Monell (Membrane)
Version		
Differential pressure switch	Electrical with 1st contact for start of cleaning, protective class IP65	Protection rating in Ex-conformant version (ATEX), Transmitter 4-20 mA, HART protocol
Control	Multi-function unit mounted (Crouzet Millennium III) / delivered separately	Allen Bradley/Rockwell, Siemens, Eexd, Explosion-protected (ATEX),
	400 V/3 phase / 60 Hz	On request
	Protective class IP64	Protection class in Ex version
Cylinder	Pneumatically activated	Electrical (depending on nominal diameter) (ATEX)
Required compressed air	6 bar	
Contaminant outlet valve	Butterfly valve	
Surface treatment, internal		
Steel housing / Cast Iron	Corrosion protection oil / Chemonit 33 (rubberlined)	Chemonit 31 (rubberlined) Corrocoat, Polyglass
Stainless steel housing	Glass bead blasting or blasted	Pickled and passivated
GRP / FRP housing	Chemical-resistant vinylester liner	Corrocoat, Polyglass
Surface treatment, external		
Steel housing / Cast Iron	Epoxy in RAL 5010 blue	Customer specification
Stainless steel housing	Glass bead blasting or blasted	-
Housing GRP / FRP	GRP outer color or through-colored in RAL 5015 blue	Customer specification Polyurethane paint
Range of application of the materials according to temperature		
Steel / stainless steel housing / Cast Iron	Temperature limits: In accordance with PED or AD2000 legislation -29°C to 95°C	Special version: +120°C
GRP housing	Temperature limits: -70°C to +60°C	Special version: +120°C
Design/Certification	Declaration of Conformity, 3.1 Material Certificates – Lloyds Register certified foundry acc. to DGRL 97/23/EC for cast iron (GGG50/ EN-GJS-500-7/ASTM 80-55-06)	ASME-Code, PED, NORSOK, DOSH, MOM, GOST, RTN

Technical data and dimensions

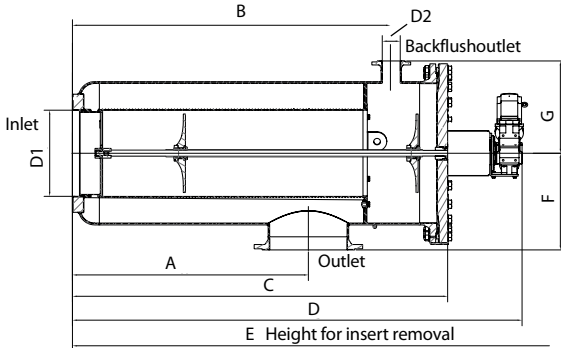

Flanges in accordance with EN 1092-1 PN 10–16 or ANSI 16.5 150 lbs

Filter dimensioning chart / Pressure loss diagram

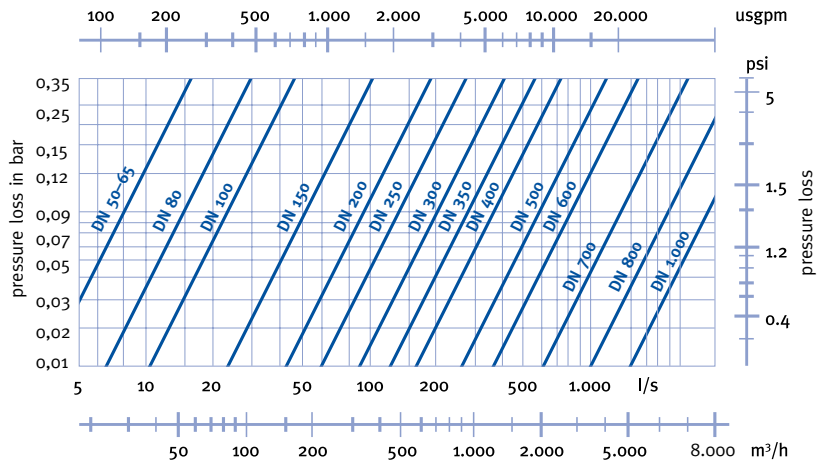

Dimension example (0.2 mm filtration degree) / selection chart at 500 m³/h, the use of a DN 250 or DN 300 is recommended at 200 µm

Material	D1	D2	A	B	C	D	E	F	G	Weight *	Flow rate ***	Example flushing volume/backflush (adjustable)
	DN	DN	mm	mm	mm	mm	mm	mm	mm	ca. kg	m ³ /h	m ³
VA/steel **	300	100	890	1155	1440	1950	2610	375	385	200	200–1100	2.2
	350	100	950	1260	1481	1990	2500	410	410	300	300–1500	2.6
	400	100	1010	1325	1535	2040	3100	485	465	450	400–2000	3.5
	500	150	1590	2205	2350	2850	3900	695	555	1600	800–3000	5.5
	600	200	1540	3055	3490	4290	4750	900	805	2300	1200–4000	9.5
	700	200	2650	3255	3750	4550	5750	1200	1100	2800	1500–5000	12.5
	800	200	2550	3300	4195	4750	7000	1060	940	3200	2500–8000	14.5
	1000	250	3100	3990	5100	6100	7700	1360	1140	1800	5000–9000	15.0
GRP	300	100	900	1280	1600	2100	2900	430	390	140	300–1000	2.2
	350	100	1000	1430	1810	2310	3170	500	450	205	300–1500	2.6
	400	100	1220	1670	2100	2600	3700	550	500	220	500–1800	3.5
	500	150	1680	2220	2700	3200	4400	650	580	550	800–2500	5.5
	600	200	1950	2570	3120	3950	4600	780	700	750	1200–4000	9.5
	700	200	2300	2990	3650	4450	4850	920	820	1000	1500–5000	12.5
	800	200	2550	3300	4100	5100	7000	1060	940	1400	2500–6500	14.5
	1000	250	3100	3990	5100	6100	7700	1360	1140	1800	5000–9000	15.0
Cast Iron (EN-GJS-500-7 / GGG-50 / ASTM 80-55-06)	300	100	890	1250	1460	1960	2540	380	450	520	200–1100	2.2
	350	100	1010	1325	1670	1990	900	485	465	650	300–1500	2.6
	400	100	1010	1325	1670	2120	2900	485	465	650	400–2000	3.5

*Dependent on pressure phase, **Rubberlined on request, ***Dependent on filtration degree





FTAF-S DN 500



FTAF-S 20" Giza

FTRF

Backflush Filter
DN 32–800 (ANSI 1 1/2–32")
PN 16–40



Applications

The FTRF backflush filter is a versatile self-cleaning, maintenance-free filter for water and conditioned process water.

Brief description and operation

The electronic control monitors the differential pressure applied to the strainer by differential pressure switch. If the preset differential pressure of 0.3 bar (0.1–0.7 bar setting possible depending on the design and application) is reached, the cleaning function is triggered. In addition the cleaning function can be triggered by a timer or manually at the touch of a button, depending on the operating conditions (as optional).

The filter consists of an vessel with three different chambers. There is a coarse screen that is used as a prefilter in the first prefiltration chamber that coincides with the water inlet (see page 69).

The water goes from outside to inside the filter. Once, the water gets inside the filter, it goes into the second chamber that is called "filtration chamber". It is in this chamber where the filtering element is: the FILTRATION SCREEN, made of stainless steel.

In this case water runs from the filter interior into the exterior. The solids remain in suspension held back in the filtering element.

The held back particles forms a layer on the screen that diminishes its load. The filter backwashing bases on a third chamber, the backwashing chamber whose output is connected to the drainage valve that allows water evacuation when the backwashing process starts. The backwashing chamber is separated from the filtering by a special sealing.

To finish with, as a very important element of this technology is the SUCTION SCANNER. This scanner is the same place as the filtering cartridge central shaft would be, and it is hydraulically connected to the backwashing chamber. At the same time, and in the filtering chamber area where it is, the SUCTION NOZZLES are displayed perpendicularly. The nylon brushes nearly reach the screen. The situation of these nozzles in the suction scanner has been studied for getting into contact with the screen internal surface, thanks to the spiral movement that the electric motor provides to the scanner: when combining a longitudinal and rotation movement.

The cleaning effect

The filter cleaning effect is created by the described reverse of flow / backflush through from the clean side of the screen (filtered water side) through the SS mesh, the nozzle, the cleaning chambers finally to the drain. Therefore the cleaning effect is influenced by the working pressure – or the pressure at the OUTLET of the filter. The higher this pressure during backflush is – the better the cleaning will be. The minimum pressure during backflush is 2.3 bar at 125 micron (example). When the filter mesh gets finer the necessary backflush pressure has to be higher. This is a project individual requirement and also based on the water quality. Therefore a dimensioning of FTRF filter shall be done / checked by Fil-Tec experience. If the pressure is not sufficient there are possible measures like; increase of pressure during backflush activity only (signal to a external pump by PLC (optional) or other measures like reducing flow in outlet for a short time during backflush by control valve.

Performance

- Water gets into the filter through the prefiltration chamber, where thick particles are retained, as it was a strainer.
- Water gets into the filtering chamber, goes through from inside to outside the FILTERING SCREEN. High quality water is obtained according to the filtration degree chosen for the filtration screen which can vary from 10 microns to 2000 microns.
- Dust remains on the thin screen interior what produces head loss between the filter inlet and outlet gradually. Two analogic transducers will indicate the backwashing sequence when the DP becomes 0.3 bar. There are other possibilities to make the filter backwashing: Time backwashing's, time and pressure combination, continuous backwashing option.
- When the pressure switch indicates 0.3 bar, the drain valve receive the opening order, then it generates a pressure difference between outside (atmospheric pressure) and the inside of the filter (working pressure) that is why fast running water which is produced, goes through the screen and then goes outside through the nozzles internal orifice.



Technical data

- Besides this, at this very moment the starting order is also sent to the engine.
- The result of these actions is: the suction effect of the nozzles on the screen dust and the suction scanner spiral movement in the inside of the filter. The necessary working pressure at filter outlet is minimum 2.3 bar – see also point NOTE at “Brief description”. For fine filtering below 100 micron and depending on water quality the necessary working pressure shall be over 3.0 bar. Higher working pressure is positive for cleaning.

- During the backwashing process that lasts 25 seconds for most models, water is still being filtered and goes on flowing to the system or application. This fact which is due to the filters design allows that the backwashing water consumption is MINIMUM and the working system is CONTINUOUS.

Filtration is not interrupted during the backflush process in a system. After the set flushing period elapses the contaminant outlet valve closes automatically.

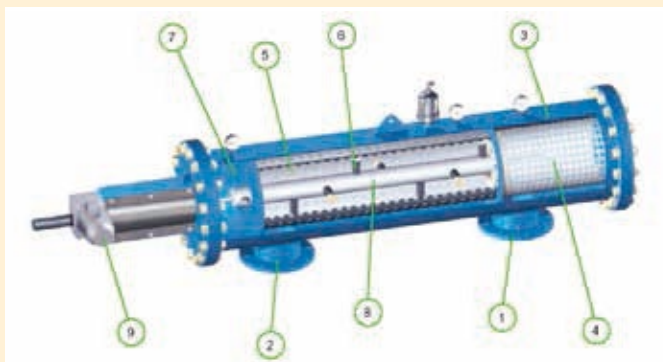

- | | |
|-----------------------|---------------------|
| 1 Inlet | 6 Filtering chamber |
| 2 Outlet | 7 Flushing chamber |
| 3 Strainer chamber | 8 Scanner |
| 4 Strainer cartridge | 9 Motor drive |
| 5 Filtering cartridge | |

	Standard version	Special version or optional extras equipment
Filter insert	10–3.000 µm	
Filter cover	Cover with bolts and nuts	
Venting device	Screw	Ball valve
Drain unit	Screw	Ball valve
Connections	Flange in accordance with DIN 2632/Form C PN 10	ANSI or in accordance with customer specifications, PN 16, PN 25
Materials		e.g. ANSI
Housing	CS carbon steel (Epoxy + Polyester)	SS304, SS316/1.4571, H II steel, CrNi, 1.0425
Seals	NBR	PTFE/FPM, other
Perforated plate/mesh	1.4301/SS304/PVC	1.4404/SS 316L/POM
Cleaning nozzle		
Drain valve	By client	St, Ms, A , A4
Electric gear motor	3 x 400 V/50 Hz protection class IP 65	As specified by customer
Control	not attached With transformer 500 V/400 V/230 V – 50 Hz/ 60 Hz, protection class IP 65, programmable	Attached on the filter as specified by the customer
Flush outlet valve	Hydraulic operated valve brass MOC	Rg 5, A4 Electro-pneumatic (230 V - 6 bar) / (24 V - 6 bar) Protection class IP65
Surface treatment		
Interior	Epoxy + Polyester	
Steel housing	CS (Epoxy + Polyester)	epoxy-resin paint, hard rubber
Surface treatment		
Exterior	Epoxy + Polyester	
Housing	Glass balls sand blasting	
Steel 304 housing steel		
Stainless steel 316 housing	Glass bead blasted	Pickled and passivated

Technical data and dimensions

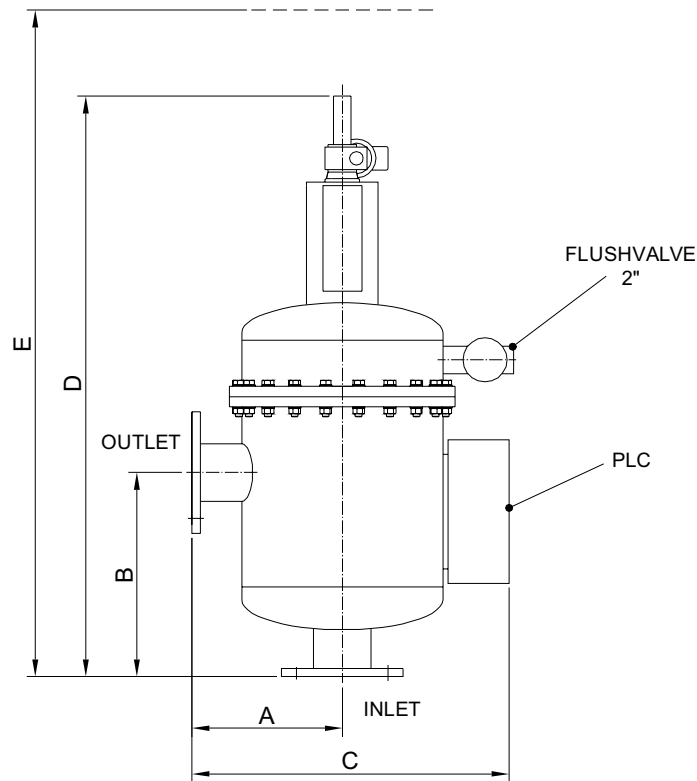

Model	In/Out Connect	Dimensions (mm)				
		DN	A	B	C	D
FTRF-C GR2	50	220	220	480	900	1.150
FTRF-C GR3	80	220	250	480	980	1.230
FTRF-C GR4	100	260	320	590	1.100	1.340
FTRF-C GR6	150	260	470	590	1.375	1.615

* Flow figures are based on 100 / 125 micron and depend on water quality and filter mesh. So the actual allowed flow may vary. Contact Fil-Tec for exact dimensioning.

Model	Filtering surface (cm ²)	Backwashing water consumption (l)	Weight (kg)	Flow rate (m ³ /h)*			
				Max. flow rate	High quality water	Medium quality water	Low quality water
FTRF-C GR2	1.015	8	43	70	35	25	10
FTRF-C GR3	1.770	12,5	54	140	60	40	20
FTRF-C GR4	2.655	15,5	68	200	80	60	30
FTRF-C GR6	5.315	53	89	350	120	100	60

Technical data and dimensions

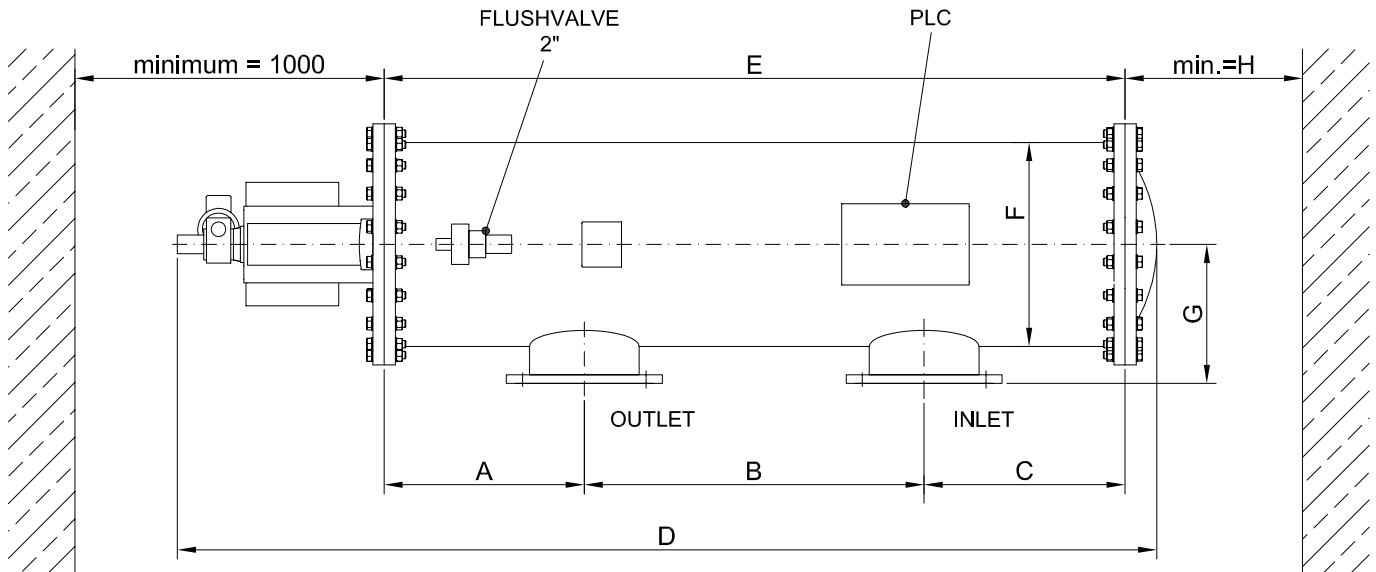

Model	In/Out Connect	Dimensions (mm)							
		DN	A	B	C	D	E	F	G
FTRF GR3	80	302	360	219	1.625	881	457	325	400
FTRF GR4	80, 100	315	770	220	2.140	1.305	457	325	690
FTRF GR6	80, 100, 150	340	1.000	240	2.415	1.580	457	325	970
FTRF GR8	100, 150, 200	367	1.100	388	2.690	1.855	457	325	1.240
FTRF GR10	150, 200, 250	446	1.370	314	2.965	2.130	457	325	1.520
FTRF GR12	200, 250, 300	430	1.100	325	2.707	1.855	660	450	1.240
FTRF GR14	250, 300, 350	433	1.370	327	2.982	2.130	660	450	1.520

* Flow figures are based on 100 / 125 micron and depend on water quality and filter mesh. So the actual allowed flow may vary. Contact Fil-Tec for exact dimensioning.

Model	Filtering surface (cm ²)	Backwashing water consumption (l)	Weight (kg)	Flow rate (m ³ /h)*			
				Max. flow rate	High quality water	Medium quality water	Low quality water
FTRF GR3	2.657	35	265	120	60	48	34
FTRF GR4	5.383	70	307	235	110	90	70
FTRF GR6	7.997	105	388	500	215	173	129
FTRF GR8	10.608	140	444	700	320	256	192
FTRF GR10	13.215	175	501	1.150	580	464	348
FTRF GR12	16.509	140	682	1.400	700	560	420
FTRF GR14	21.304	175	757	1.800	900	720	540

Head loss Graph

Head loss Graph FTRF 50 µm

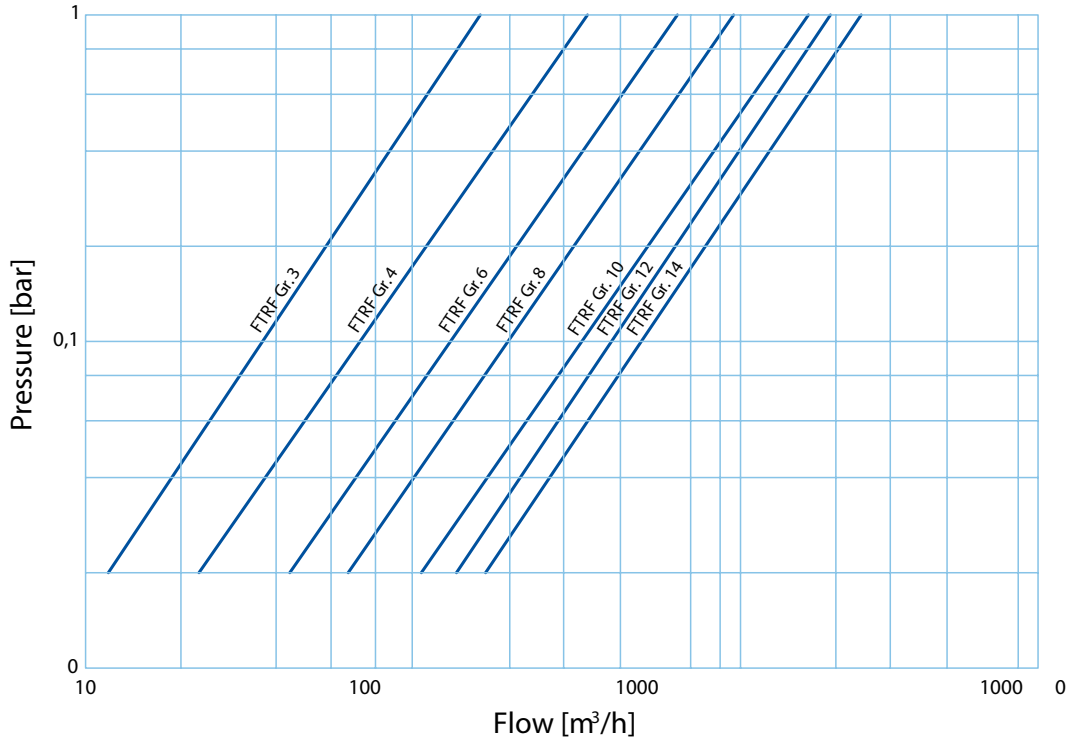

Head loss Graph FTRF 80 µm

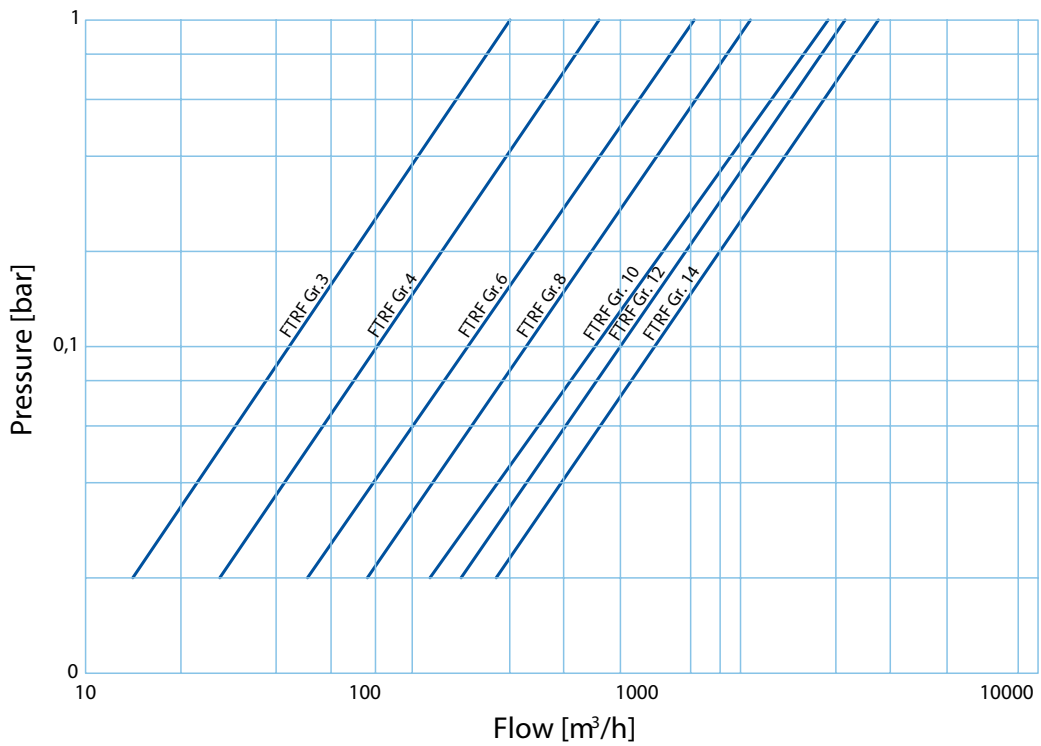

Head loss Graph

Head loss Graph FTRF 125 μm

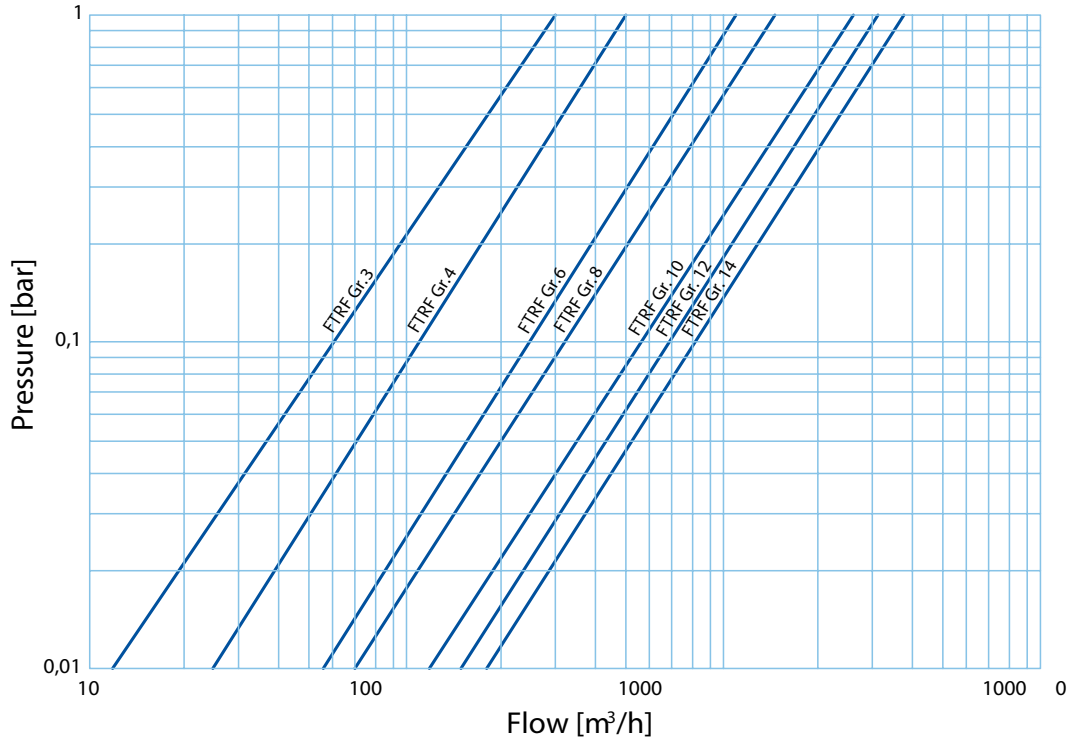

Head loss Graph FTRF 1500 μm

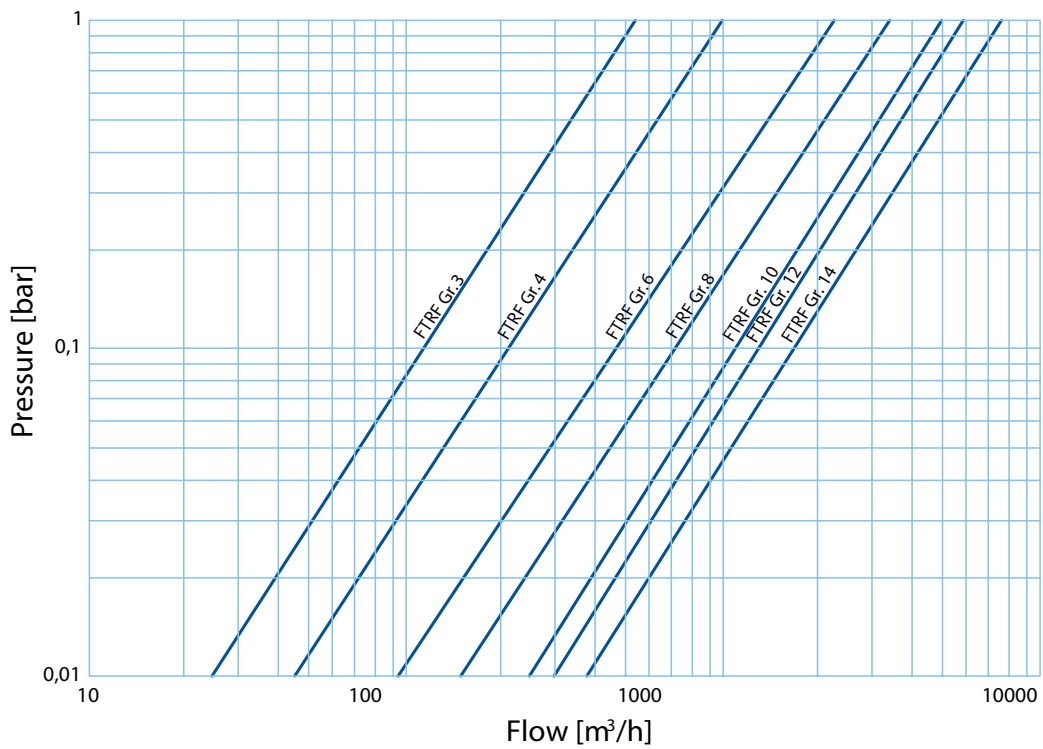

Fil-Tec Differential-Pressure Indicator Type : FT4.36.2

Application

Build-up of differential-pressure across the Filter is a measure of the degree of contamination on the filterelement. The Fil-Tec Differential-Pressure Indicator is rugged, compact and designed to allow the condition of the filter-element to be checked at a glance. As the pressure-differential increases, the display increasingly shows a red-face in direct proportion to the contamination of the element. The pre-set maximum value of differentialpressure is reached when the display shows an all red-face. The operator at all times can thus monitor the filter's performance. The Differential-Pressure Indicator FT4.36.2 is equipped with integral electrical contacts. The 2 independently switched outputs can be used either as switches or as alarm-contacts.

Design and Operation

Housings of Differential-Pressure Indicators are made of coated die-cast aluminium: The piston is held in 'Zero' position by a spring. As differential-pressure rises with increasing contamination, the piston is displaced against the force of the spring, a movement which is converted magnetically into rotation of the indicator-disc corresponding to the displacement of the piston: with the result that red areas appear in the visual display. When the windows show all-red, the maximum value of the pre-set differential-pressure range has been reached. The Fil-Tec Differential-Pressure Indicator Type : FT4.36.2 reads at-filter; and also signals alarm at main Control-panel the contacts of the 2 reed-switches are activated magnetically, respectively at 75 % and 100 % of differential-pressure's maximum value as pre-set. All Differential-Pressure Indicators are set for the differentialpressure range required for the Plant by installation of appropriate springs, factory-fitted.

Technical Data

Circuit-diagram

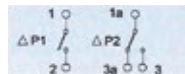

Protection-class	: IP 65
Switched voltage	: 230 V
Frequency	: 0-60 Hz
Operating pressure (max.)	: 160 bar
Operating temperature (max.)	: 150 °C
Differential press. range	: 0,5; 0,8; 1,2; 2,0; 3,0 bar

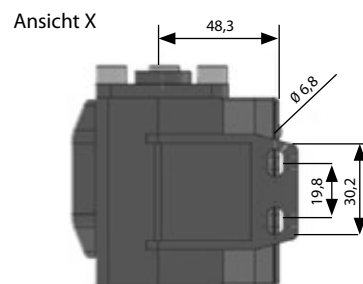
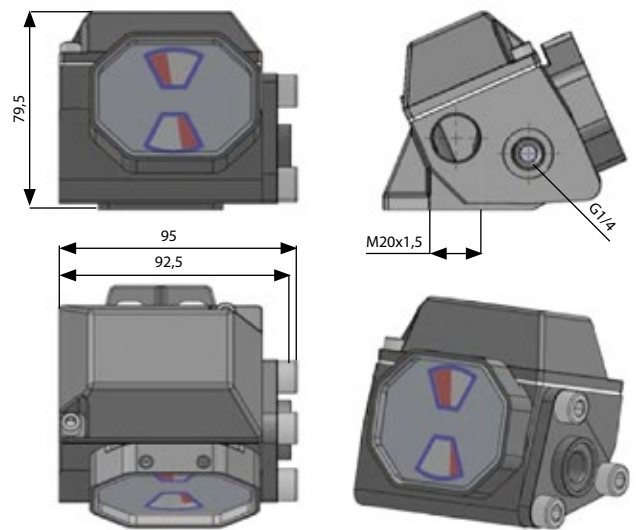

Modern production of filter aids

The term “filter aids” refers to all filter elements that can be inserted into various housings, in other words, the heart of the filtration. At FIL-TEC RIXEN GmbH, this production is carried out according to the latest criteria, thus making us the market leader.



Fig. 1

After procurement of the certified raw materials with 3.1B inspection certificates, the required parts are first cut to size on a fully automatic saw (Figure 1), and then finished on state-of-the-art CNC turning and milling centres (Figure 2). Afterwards, the workmanship of the batches

is checked using precision measuring instruments. The parts thus created then join the picked accessories that are needed, and are passed on for further processing or assembly. Some filter elements, such as basket elements, mantle elements or pleated elements might require welding work, which is carried out with the latest welding equipment (roll-welding, spot welding, MIG / MAG / TIG / plasma welding) (Figure 3).



Fig. 2



Fig. 3

The so-called pleats are produced on a pleating machine (manufactured by the Rabofsky company) (Figure 4).

The machine is able to process all conventional materials (paper, fabric, stainless steel mesh, etc.). After the individual items have been picked, the components are then assembled.



Fig. 4

This takes place in a „clean room“, which is slightly pressurised, thus guaranteeing absolute purity (Figure 5). This ensures that final assembly is particle-free. The bond is often seen as the seal between the impure and the clean side. After the elements, such as candle filters, have been completed, they are subjected to a so-called „bubble point test“ (Figure 6).

This test tells you whether the separation between dirty and clean space meets the requirements, whether the mesh corresponds completely to the filtration grade after



Fig. 5

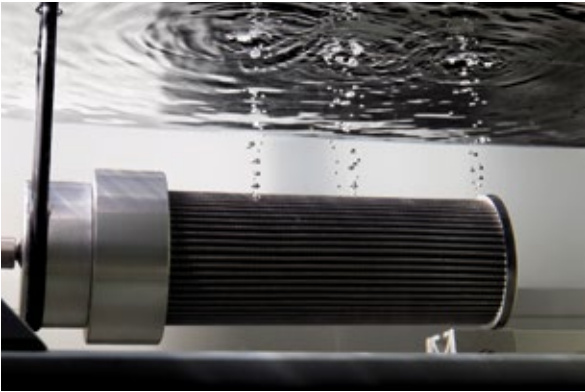

Fig. 6

completion, and whether any bypass currents are present. This would have disastrous consequences, a fact which is treated negligently by some manufacturers. There are some companies on the market who try to copy the products, but do so without having any experience, background knowledge or quality control. Their products fall far short of the high standard of quality found in the products from FIL-TEC RIXEN GmbH.

We at FIL-TEC RIXEN GmbH use only certified material from Germany and Switzerland, with certificates of approval from the owner / operator. This is the only way to ensure a long service life and trouble-free operation. The elements are intended to protect downstream units from damage. FIL-TEC RIXEN GmbH, with over 25 years of experience can guarantee that.

After the filter elements (filter aids) have been completed, they are equipped with seals made of various materials, depending on the application. The elements are then labelled using a new laser machine (Figure 7). In addition to our logo „FT“, the type designation, the filter grade indicated in μ absolute, and the date of manufacture are engraved by laser. Afterward, the elements are placed in a shock-proof package and sent to the warehouse.

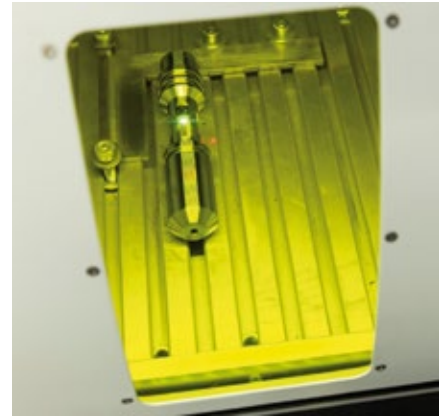

Fig. 7



Due to its flexibility, FIL-TEC RIXEN GmbH can produce small batches, large batches, as well as customised individual pieces. Quite a few customers make use of this know-how, especially when it comes to elements that can no longer be obtained on the market.

Our goal is to produce filters of the highest precision to meet the specific requirements of our customers. The trained and highly qualified experts at FIL-TEC RIXEN GmbH always find the right solution to meet the challenge of the task and specifications. In addition to the filter aids described here, FIL-TEC RIXEN GmbH offers complete housing and system solutions.

Candle filters

In the production of Fil-Tec candle filters, which are used for purifying lubricating oils, fuels, coolants, and other fluids, our special manufacturing process ensures that the candle filter sock is pulled on properly. The Fil-Tec candle filters are fitted with different types of mesh, depending on the requirements of the engine manufacturers or operators of industrial plants. We can also provide complete candle filter inserts.

The Fil-Tec candle filters are available in both polyester design as well as various in stainless steel mesh designs.



Polyester candles, wedge wire candles, wire-mesh candles



Candle filter with stainless steel mesh and protective sock

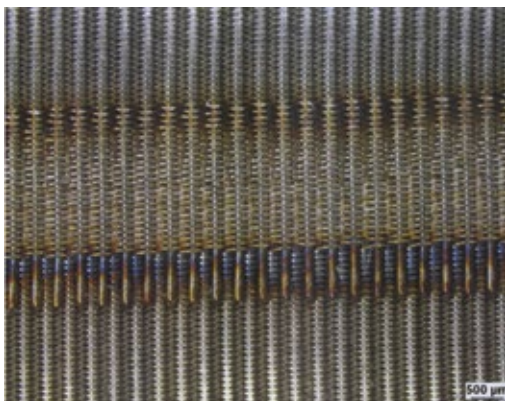

Fil-Tec weld seam

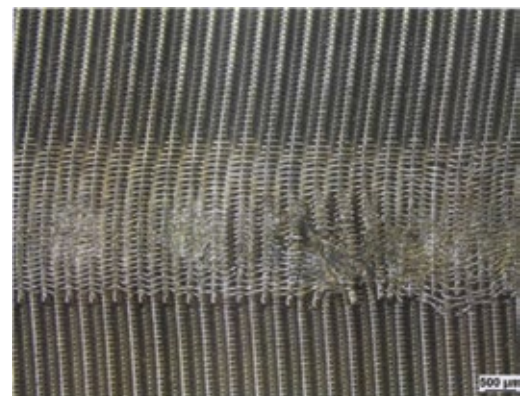

Low cost supplier: Weld seam

The candle filters from Fil-Tec are characterised by meticulous workmanship. Mechanical tests show that the mesh is generally welded with great care, so that hardly any deformations are exhibited in the mesh. This way, widening of the mesh, which could result in a by-pass for larger particles, is avoided.

Comparison to other manufacturers

	FIL-TEC RIXEN GmbH	Other manufacturer
Type of seam	Roll seam (without deformation)	Roll seam (with deformation) or spot-welding
Wire projection	Long straight	Long deformed
Anomaly	-	Widening of the mesh / deformation of the surface

The candle filters supplied by Fil-Tec are available in two different versions. They are installed by either plugging them in or screwing them in.

The salient features of the Fil-Tec plug-in candle filters are:

- resistance to alkaline cleaners
- caps are made of steel or stainless steel

The screw-in elements for fully automatic backwashing filters are at the cutting edge of development – thanks to the many years of experience of the Fil-Tec engineers. Besides the advantages of the plug-in candle filters, the screw-in elements are optionally protected against mechanical damage by a protective mesh.



The candle element inserts can be used as an alternative to mantle elements and also be used for the newest generation of duplex filters with guaranteed leak-proof switchover.

The candle element inserts offer the following advantages over the mantle elements:

- approx. 36% larger filtering surface (depending on the filter size)
- extended service life
- fewer components (seals)
- the candle is ideally protected by the sock (optional)
- candles are individually replaceable
- easier to clean

Candle filters

Comparison of polyester mesh material from FIL-TEC RIXEN GmbH, original, other suppliers.

In order to always offer you the right product at competitive prices, all of the mesh material we use is tested and technically approved, and we only use mesh with identical technical parameters. Below is a comparison of the mesh used in the polyester candles by the original manufacturer, by the FIL-TEC RIXEN GmbH and by a low cost supplier.

		Fil-Tec Rixen GmbH FT1360014	Original 1360014	Low Cost Supplier
Candle		FT1360014	1360014	
Structure		3-layer construction on metal wire support	3-layer construction on a flat plastic support	3-layer construction on a flat plastic support
Filter material		open mesh material, circular woven, 3/1 twill	open mesh material, circular woven, 3/1 twill	open mesh material, circular woven, 3/1 twill
Strand/cm warp		83	88	78
Strand/cm weft		72	69	62,5
Mesh size warp	µm	60	60	60
Mesh size weft	µm	25	20-25	40 *
Air permeability	l/m ² /f	1295	1320	2540
Test medium		Water	Water	Water
Temperature	°n	19	19	19
Viscosity	mPas	1	1	1
Test flow rate	l/h	2700	2700	2700
Diff pressure	bar	0.06	0.05	0.04
Flow velocity	m/f	0.0549	0.0549	0.0549
Operating medium		Lubricating oil	Lubricating oil	Lubricating oil
Temperature	°n	100	100	100
Viscosity	mPaf	20	20	20
Flow velocity.	m/f	0.0158	0.0158	0.0158
Diff. pressure filter mesh (for laminar flow)	bar	0.34	0.29	0.23
Difference in dp compared to the original	bar	0.05	0	-0.06
Separation compared to original		25 % better **		100% worse **
Outside diameter mm		18.5	18.5 – 18.7	19

* Testresult from the original manufacturer of filter-fabrics.
The original manufacturer specifies a max. mesh size of 30 µm.

** Less air permeability in comparison / quotient to the original product.

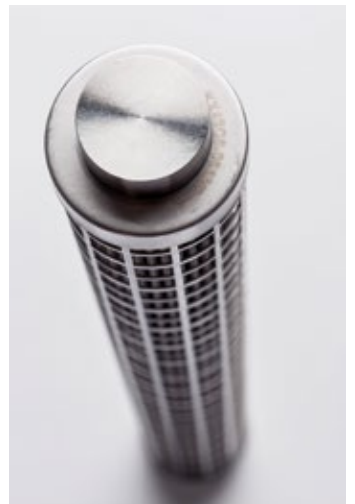

Results from the use of candle filters with significantly higher filtration grade

(see table Fil-Tec, Original 25 µm Low Cost Version 40 µm)



Bearings after a running time of 15,000 hours

Multi-mantle filter elements



The multi-mantle filter element consists of several cylindrical filter mantles. This design provides a large filtration surface with a small space requirement and allows the use of the finest filter mesh.

Original mantle elements for a variety of applications are available in all standard sizes and grades of filtration from our warehouse in Hamburg.

Fil-Tec will also overhaul your used filter elements and return them to you in a like-new condition.

Technical Data:

Application	:	Duplex and simplex filters
Filtration grades from/to	:	10 µm – 2000 µm
Filter media	:	Stainless steel wire mesh
Gross filter area from/to	:	300 cm ² - 85400 cm ²
Cleaning	:	Ultrasonic bath / manual cleaning

Pleated filter elements



Depending on their design, the new generation of pleated filter elements produced by Fil-Tec can be used to filter a wide variety of fluids, such as lubricants, fuels, hydraulic fluids, washing liquids, cooling lubricants, etc. In spite of their compact construction, they offer the largest possible filtering surface area.

Technical Data:

Application	: Duplex and simplex filters
Filtration grades from/to	: 10 μm – 250 μm
Filter media	: Stainless steel wire mesh
Gross filter area from/to	: 690 cm^2 - 105742 cm^2
Cleaning	: Ultrasonic bath / high-pressure cleaning with spray lance and rotating jet / manual cleaning



Candle filter inserts

The candle filter inserts consist of several parallel-connected candle filters (plug-in candles or screw-in candles). Compared to multi-mantle filter elements, these offer a larger filtering area in the same amount of space, which allows higher flow rates. Due to their design, candle filter elements have a greater differential pressure resistance.

During the production of Fil-Tec candle filters, which are used primarily for filtering lubricating oils, our special production methods ensure that the filter sock is fitted properly. The Fil-Tec candle filters can be made from a wide variety of materials depending on the requirements of the engine manufacturers or the operators of industrial plants. We also can supply complete candle filter inserts.



Technical Data:

Application	:	Duplex and simplex filters
Filtration grades from/to	:	10 µm – 200 µm
Filter media	:	Stainless steel wire mesh
Gross filter area from/to	:	600 cm ² - 73810 cm ²
Cleaning	:	Ultrasonic bath / high-pressure cleaning with spray lance and rotating jet / manual cleaning

Basket elements



Basket elements are used for coarse filtration or lower concentrations of dirt. The dirt is collected in the basket of the filter insert, which can be easily removed for cleaning.

Technical Data:

Application	:	Duplex and simplex filters
Filtration grades from/to	:	70 μm – 5000 μm
Filter media	:	Stainless steel wire mesh
Gross filtration area from/to	:	140 cm^2 - 12475 cm^2
Cleaning	:	Ultrasonic bath/manual cleaning



Ring element

In order to increase the filtering surface area in basket elements, in a ring element an additional fabric cylinder is installed in the centre of the element. This increases the filtering surface area by approx. 30 %.



Technical Data:

Application	:	Duplex and simplex filters
Filtration grades from/to	:	70 µm – 2000 µm
Filter media	:	Stainless steel wire mesh
Gross filtration area from/to	:	1214 cm ² - 16435 cm ²
Cleaning	:	Ultrasonic bath/manual cleaning

Candle filters / elements for automatic filters



Candle holders already equipped with candles for easy replacement of the elements in automatic filters.

Technical Data:

Application	:	Automatic filter
Filtration grades from/to	:	Depending on the application
Filter media	:	Stainless steel wire mesh, polyester mesh, gap filters
Gross filtration area from/to	:	Depending on the application
Cleaning	:	Ultrasonic bath / high-pressure cleaning with spray lance and rotating jet / manual cleaning

Filter components and accessories



Besides developing and improving filter elements, Fil-Tec also offers a comprehensive service surrounding the supply of filter components and accessories. For the new generation of fully automatic backwashing filters, Fil-Tec uses exclusively quality filter components either from its own production or from other German manufacturers producing with state-of-the-art methods. In order to ensure the correct function of the older generation of fully automatic backwashing filters, we also supply a complete range of first-rate, German manufactured components for these types of filters.

We are also able to custom manufacture any spare part for older automatic filter types on the basis of a sample or drawing, if required.

Of course, as part of Fil-Tec's complete filter service, we are also able to supply quality-tested accessories, such as pneumatic equipment accessories, electrical parts, valves, seals, etc.

Call our sales office. We guarantee the shortest possible delivery times from our warehouse in Hamburg.

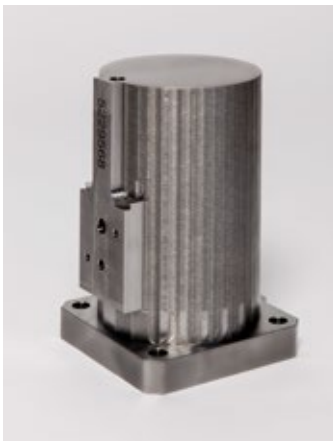



Fil-Tec disposable elements for the processing of flushing fluids and flushing oils



The Fil-Tec disposable elements are made of high-quality filter paper. The pleated filter elements offer the largest possible filtering surface area in a minimal requirement of space, thus ensuring a long service life.

The filter insert used for flushing oil shown here is equipped with paper elements (50 µm or 10 µm). These elements can be adapted to any size filter and are used after bearing repairs or work on bearing journals (milling).



Technical Data:

Application	:	Simplex and duplex filter, flushing oil processing
Filtration grades from/to	:	10 µm – 150 µm
Filter media	:	Stainless steel wire mesh, paper, fibreglass, polyester
Gross filtration area from/to	:	Depending on application

Control systems for automatic filters

For automatic backwashing filters, Fil-Tec also supplies its own, internally developed control systems ranging from highly reliable analogue controls to fully electronic controls, as well as a newly developed PLC based on Siemens components, which is characterised by self-explanatory, easy-to-program parameter settings.

All of the components used come from renowned German manufacturers.

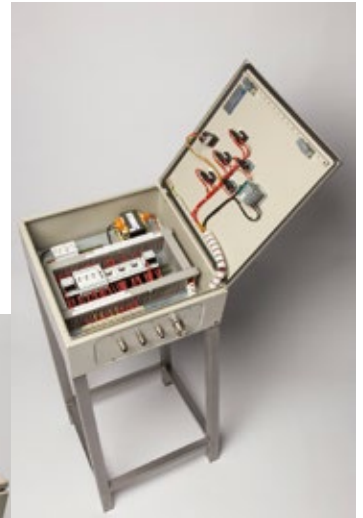

Fil-Tec analogue controls



New PLC from Fil-Tec

Fil-Tec production and major overhaul of complete filters

At Fil-Tec-Rixen GmbH we not only distribute the wide range of products of a renowned filter manufacturer, but also we possess the technical know-how required for the development and manufacture of our own filter elements.

The original Fil-Tec-Rixen filter elements and filter components from our own production are manufactured for existing filter installations.

You can now receive our high-quality technical products in any desired quantity and specification at short notice.



Replacement filter elements for Nantong

Fil-Tec offers a number of enhanced solutions for this Chinese manufacturer of filters and filter elements, which are characterised in particular by the following properties:

- Larger filtration surface due to the use of pleated elements instead of filter discs
- Easier handling
- Only two seals as opposed to two seals per disc
- Pleated elements fit on existing holders
- Holders are also available and easily installed
- Use of German-manufactured standard mesh (10 µm, 25 µm, 34µm, 48µm, 60 µm, 80 µm, or other filtration grades on request).



Replacement filter elements for Kanagawa Kiki



Custom-made products and improved special solutions

All of the filtration solutions developed by Fil-Tec are characterised by the use of the largest possible filter surface areas, reliable materials, ease of handling, and lower sensitivity to mechanical damage. Kanagawa Kiki filter elements can also be replaced by Fil-Tec products or repaired to a like-new condition.

Choose from our wide range of notch wire alternatives.

Problems with notch wire filter elements

Problem: There is an increasing incidence of engine damage caused by destroyed “notch wire elements,” especially right after major overhauls or improper cleaning of the filter elements. A major disadvantage of these filter elements is their design. A wire is wound around a cast aluminium core with pre-determined spacing achieved with the help of spacers. If at some point the length of wire becomes damaged, the entire filter element will fall apart.

Solution: Fil-Tec uses only German-manufactured mesh. Whenever possible, the fine filter core is protected by an additional fabric sleeve, which prevents mechanical damage, especially during installation/removal and cleaning of the filter elements.

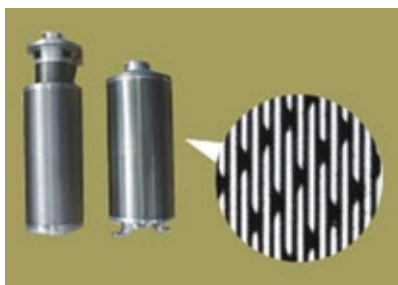

Structure of the notch wire filter elements



Filtering principle of the notch wire filter elements

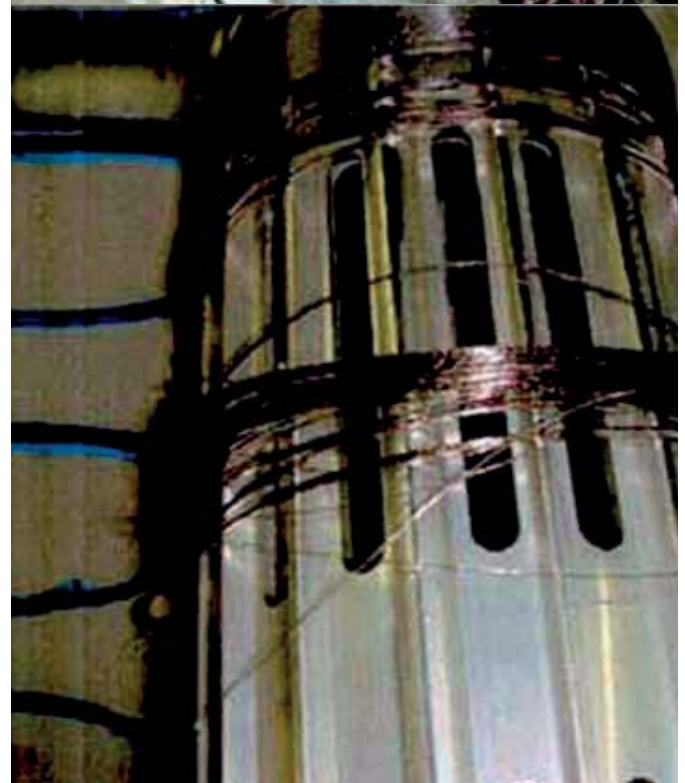

Filter elements and replacement parts for automatic filters produced in Italy

Due to our many years of experience in the construction of filter elements and the production of replacement parts, we can also offer filter elements for the existing systems of other manufacturers, for instance Filtrex in Italy.

Our database of replacement parts and filter elements continues to grow steadily through our cooperation with the operators of these systems.

Have you also had problems finding replacement parts or are the prices for these products too high?

Call us – together we will find a sophisticated solution in both technical and economical terms.



Filter elements to match Moatti filters

Likewise, we have also compiled a wide range of replacement parts for Moatti filters, so that the primary spare parts, such as filter discs in various sizes and filtration grades, seals, O-rings and mechanical parts are ready for delivery from our warehouse in Hamburg.



Water filter cartridges, housings and complete systems with pumps

Besides cartridges of different sizes and materials, you will also find filter housings to meet every need, from the simplest household application to complete water treatment systems.



Perfect solution for the filtration of heating circuit water or as a pre-filter for bilge oil separators

Fil-Tec air filters

Air filter pockets for shipping and industry, as well as filter mats for turbochargers and generators can be ordered in different qualities and strengths from Fil-Tec.



Standard sizes and designs pocket filters

Qualities	:	G3, G4, F5, F6,F7, F8, F9
Frames	:	Metal (M), plastic (P)
Standard sizes	:	287x592 mm, 490x592 mm, 592x592 mm, 592x287 mm, 592x490 mm, 287x892 mm, 490x892 mm, 592x892 mm
Number of pockets	:	3, 4, 5, 6, 10, 12 (depending on the dimensions)
Length of pockets	:	200 mm, 300 mm, 360 mm, 500 mm, 600 mm
Frames	:	25 mm

Standard sizes and designs panel filters

Qualities	:	G2/EU2 (Glas), G3/EU4 (synthetic), fibreglass, G4-F5 on request
Frames	:	Cardboard frame
Standard sizes	:	292x596x24/48 mm, 393x495x24/48 mm, 393x622x24/48 mm, 495x495x24/48 mm,
(Width x Height x Depth)	:	495x622x24/48 mm, 596x596x24/48 mm
Frames	:	24 mm, 48 mm

Standard sizes and designs Z-Line filters

Qualities	:	EU4/G4, EU5/F5 (synthetic fibre) , F6-F9 on request
Frames	:	Cardboard frame, metal or plastic frame on request
Standard sizes	:	285x592x46/96 mm, 395x492x46/96 mm, 395x622x46/96 mm, 492x492x46/96 mm,
(Width x Height x Depth)	:	492x622x46/96 mm, 592x592x46/96 mm
Frames	:	46 mm, 96 mm

More sizes, filter classes and frame types on request

Paint and drying technology

Spray-painting applications have to be provided with large quantities of purified air for reasons of operational safety, air quality control and hygiene. In order to protect the coating against contamination by airborne particles, the effective filtration of the supply air and circulating air is indispensable.

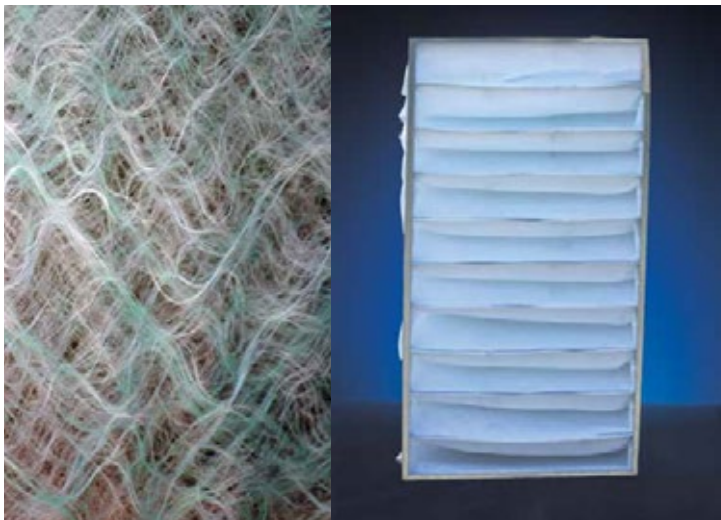

Floor and ceiling filters

Paint-Stop green/white, for filtering out paint mist in paint-spray lines, baking chambers and spray booths. Available as a standard roll in various strengths or cut to your specifications.

Pocket filters

For filtration in ventilation systems and units of all kinds.

Primary use:

- Pre-filter for fine particulate filters
- Pre-filter for paint-spray lines

Filter cartridges for lubricating oil and fuel



FIL-TEC RIXEN sells quality products of leading brand names

As an authorised dealer of Stallion, MANN+HUMMEL Centrifuges, Cummins (Fleetguard) and Bosch-Rexroth, we can offer the entire retail product range to choose from.

You will also receive comparable OEM qualities from leading manufacturers at low prices.

Quickly and reliably.



Filter elements for lubricating oil and fuel produced by Fil-Tec



As a technically identical alternative to OEM products, we also offer disposable cartridges from our own production bearing the FIL-TEC RIXEN GmbH brand name. The array of elements shown here is only a small selection of our extensive product line available in our warehouses in Hamburg and Singapore.

Hydraulic filter elements

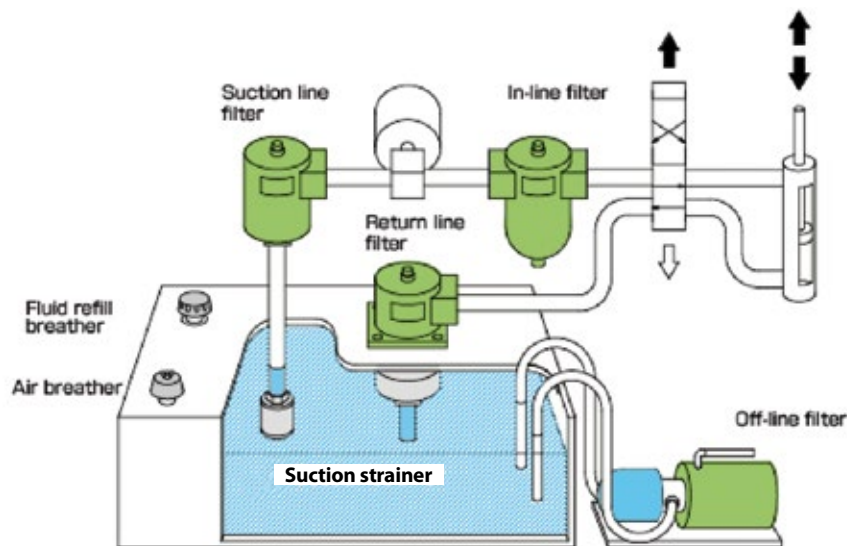

Standard hydraulic system

Fil-Tec hydraulic filter elements fit into almost all conventional hydraulic systems. They are manufactured the same way as the so-called „original filter elements“ in terms of quality and dimensional accuracy. Our extensive stock ensures you quick access to all common hydraulic filter elements (return line filters, high pressure filters, medium pressure filters and suction line filter) to fit your needs.

We are an authorised representative of Bosch Rexroth GmbH, among others.

Rexroth
Bosch Group

Filter elements produced on the basis of a sample or drawing



FIT INTO EXISTING INSTALLATIONS DUE TO THE STRUCTURALLY IDENTICAL DESIGN.
Fil-Tec filter elements have the same specifications as the original parts in existing installations. This ensures that they meet all of the technical requirements and can be used without reservations.

GUARANTEE TROUBLE-FREE USE DUE TO HIGH PRECISION & RELIABLE TECHNOLOGY.
Fil-Tec filter elements from our own production are manufactured using conventional filter materials and are subject to strict quality control while conforming to international standards.

ALLOW DELIVERY AT SHORT NOTICE THANKS TO EFFICIENT WAREHOUSING.
Our well-stocked warehouse at Fil-Tec enables immediate shipping of the desired elements, allowing you to access parts at short notice without having to stock supplies yourself.

Oil separator cartridges and accessories

You can also obtain cartridges for the separation of oil and water (bilge water purification) from Fil-Tec. Our extensive product range includes all popular types in terms of sizes and brand names.

Ask us about the filter element type that you are using. We're likely to have it in stock, but if not, we can manufacture it based on a sample.

You'll also find a wide variety of accessory items to fit virtually any type of oil separator.



Mobile Filtration

Mobile filtration systems for a host of applications, such as the pre-cleaning of bilge water, heating circuit water, drinking water, technical water, cooling lubricants, hydraulic oil, lubricating oil in internal combustion engines, to name just a few, are as important a part of our production and product line as completely stationary systems.



Separators in the bypass can remove contaminant particles up to 75μ from coolant and cooling lubricants without the use of filter aids. $0.7 \text{ m}^3/\text{h}$ to $1800 \text{ m}^3/\text{h}$. Particle diameters up to 9 mm . Supplied with manual or automatic sludge discharge. The operating pressure accelerates the contaminated liquid via tangential slots / holes into the separating chamber. The rotation of the liquid creates a central vortex. The resulting centrifugal forces hurl the solid materials to the outside wall of the separation chamber.

Due to the gravitational force and the flow, the solid materials sink in the calmed fluid of the collection chamber and settle at the bottom. The sedimentation is discharged at intervals. Can be used e.g. for the pre-separation of parts coming from production that have been washed, such as crankcases or cylinder heads.

Key technical data of the systems:

Output:	10-75 l/min
Temperature:	$10^\circ\text{C} - 80^\circ\text{C}$
Medium:	Water, mineral oils
Grades of filtration:	$3 \mu\text{m} - 2000 \mu\text{m}$



Presentation of a gear unit oil filtration system

Dear Mr and Mrs

We would like to take this opportunity to present you with an opportunity that can significantly reduce your operating costs. Using an example, we would like to demonstrate our long-standing experience and the resulting development to you.

- The installation of a mobile filtration system (see annex).
- Presentation of a simple filtration system
(Example: MS „CHARLOTTA B“)
Engine type: 8 cylinder MAN 58/64 11,200 KW 428 RPM
Gear unit: Renk AG Type: RSV 1160
Gear unit oil: Mobil Gear 600 XP 150
Service life: ~ 17,000 hours

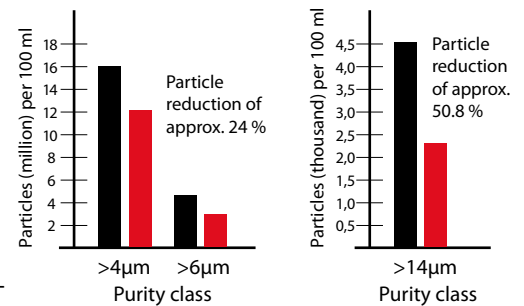

According to the oil company, the gear unit oil no longer meets the requirements and needs to be replaced. Thanks to our system and the development of ultra-efficient filtration media, we have managed to drastically reduce the level of contamination (see annex; oil examination prior to and following the examination).



We would like to emphasise that, although we were able to drastically reduce the contamination (number of particles), we were not able to affect the chemical aging of the oil.

The filtration system can also be used to clean other media such as hydraulic oil for crane systems without any problems whatsoever.

We hope that we have given you food for thought in terms of cost reduction. The system pays for itself in a short space of time, meaning that cutting the operating costs is really worthwhile.

Should you have any further questions, do not hesitate to contact our specialist department in confidence.

Yours sincerely,
Fil-Tec Rixen GmbH

Dipl.-Ing. Fritz Rixen
Fritz Rixen

Centrifugal Oil Cleaners

FM400/600/200



- Rotor dirt capacity: 4/6/2 litres
- Rotor oil capacity: 4,5/6,5/2,2 litres
- Minimum oil feed pipe size 19/19/12 mm internal diameter
- Minimum oil drain pipe size 76/76/50 mm internal diameter
- The centrifuges are available with a cleanable rotor and are equipped with paper insert to improve serviceability
- Oil inlet threads and Cut Off Valve (C.O.V.) ratings can be tailored to suit customers requirements
- For this centrifuge the following items are available:
 - ➔ mounting plate assembly
 - ➔ set of paper inserts
 - ➔ tailor made mounting brackets
- Net weight: 22/25/9,5 kg

MANN+HUMMEL

Centrifugal Oil Cleaners – the ingenious solution for many applications...



MANN+HUMMEL centrifugal oil cleaners are internationally recognised in providing superior bypass filtration for the removal of contaminant from the lubricating oil of diesel engines.

The technology can also be successfully used for gear-boxes, hydraulics and other industrial fluids.



We have received following feedback from shipping companies:

Carl Büttner GmbH & Co. KG

- "Substantially extending life of the lub oil filter for the auxiliary diesel engines after installation and commissioning of the centrifuge. The cleaning interval extended from approximately 500 hours to 1200 hours."

Reederei Bartels

- "The filter candles of the automatic filter for MaK engines had to be cleaned by hand 2-3 times during a voyage. After the installation of the centrifuge there was no need to clean by hand up to now. The reason is that the fine dirt, which clogs the mesh of the filter, is filtered by the centrifuge."

OPERATIONAL AND COST SAVING BENEFITS

Typical Rotor Performance for SAE 30 Oil @ 75 °C

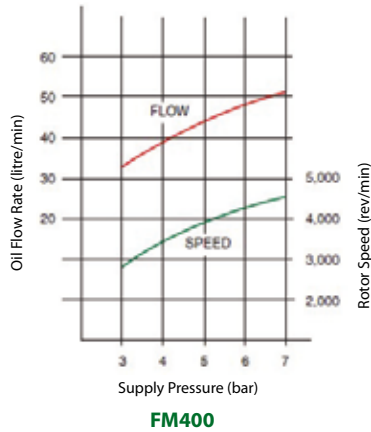

Typical Rotor Performance for SAE 30 Oil @ 75 °C

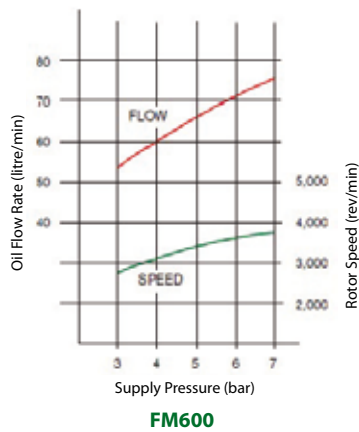

Typical Rotor Performance for SAE 30 Oil @ 75 °C

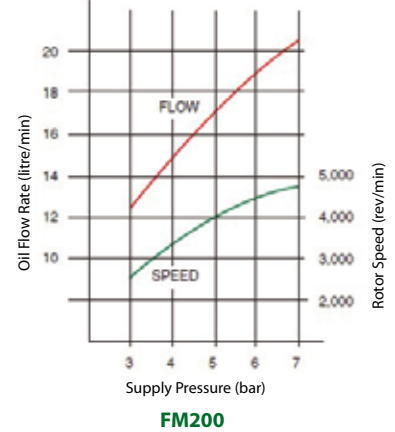

- Extended lube oil life
 - ➔ Lower costs
- Extended oil filter life
- Reduced operational and maintenance costs
- Reduced engine wear particle count
- Reduced contamination
- Lifetime component
- Few spare parts required

- Few ancillary installation parts
- Lower oil filter consumption
 - ➔ disposal / purchasing costs
- Lower oil consumption
 - ➔ disposal / purchasing costs
- Attractive return investment
- Reduced component wear
 - ➔ longer engine life
- Easier and reduced maintenance costs

- Off engine mounting
- Easy installation in Bypass
- With external Pump
 - ➔ Off engine filtration possible when oil is still warm
- Optimal rotation speed by higher pressure
(Please see graphics)



FIL-TEC RIXEN GmbH has already sold
1500 plants
for ships and industry.

Qualified advice and installation help
by FIL-TEC RIXEN GmbH.

PASSAT 
SHIPMANAGEMENT Ltd.

FIL-TEC RIXEN GmbH
Ing.-Büro für Filter-Technik
Osterrade 26

D-21031 Hamburg

Gladstonos & Androu Str.
Oasis Complex Block E, Off. C1
P.O.Box 53765
3317 Limassol - Cyprus
Telephone: +357 25 345575
Telefax: +357 25 345930
Telex: 2519 CY
E-mail: mailpassat@spidernet.com.cy

Hamburg, 10.09.2011

MS Astoria
z.Zt. in Hamburg Überseebrücke

Betr. Nachrüstung von Zentrifugen Typ FM600 mit externer Pumpe

Folgende Daten wurden aufgezeichnet:

Motor:	MAN Typ 40/45	4x	KW 3300
Typ:	Zentrifuge FM600		
Schmieröl:	Elf SAE 40		
Brennstoff:	180 cst		
Separatoren-Typ:	4x Westfalia OSA 7		
Schmieröl-Auto-Filter:	Typ 6.33 DN 200	SK 451	Filterfeinheit: 34 µm
Schmieröl-Indikator-Filter:	Typ 2.05.5 DN 200		Filterfeinheit: 60 µm



Einbau der Zentrifugen 2002/2003

Schema: Die externe Pumpe saugt aus dem Schmieröl-Umlauf tank und drückt das Schmieröl durch die Zentrifuge in den Kurbelraum. Von dort wieder Ablauf in den Umlauf tank.

Seit Inbetriebnahme der Zentrifugen wurden folgende Verbesserungen erzielt:

Die Spülhäufigkeit der Schmieröl-Auto-Filter hat sich um 30% reduziert, d.h. von vorher 70-80 Spülungen/Tag auf nunmehr 50 Spülungen/Tag. Ebenfalls damit verbunden ist die Verbrauchsreduzierung von Spülölpatronen. Zusätzlich wurden die Reinigungsintervalle der Indikator-Filter im Schmierölsystem wurden halbiert.

Abschließend kann festgestellt werden, dass sich durch den nachträglichen Einbau von Zentrifugen Typ FM600 mit externer Pumpe die Kosten für Überholung an den Schmierölsystemen sowie die kostenintensive und zeitaufwendige Reinigung der Schmierölindikator-Filter stark reduziert haben. Hinzu kommt, dass eine Analyse des Schmieröls durch den Lieferanten ein ABSOLUT BESSERES Ergebnis zeigt. Die Feststoffe im Schmieröl (Tuol-unlösliche Teile, die von der Verbrennung herrühren), wie z.B. Koks etc., weisen einen deutlich geringeren Anteil auf.

Die Maschinenleitung der MS Astoria ist mit dem Ergebnis mehr als zufrieden.



Directors: D. Rodemund, Chr. Georghiades
Banks: Hellenic Bank Ltd., Limassol/Cyprus • Account No: € 240-07-173750-01, CE 240-01-173750-01
Bremer Landesbank, Bremen/Germany • Routing Code: 290 500 00 • Account No: € 100 3587 003





The specialists for filters in marine and industrial applications

Information für unsere Kunden Januar 2008 Erfahrungsbericht Ch. eng. MV Hansa Riga

Report of Centrifuge installation :

MV Hansa Riga

Leonhardt & Blumberg

Centrifuge: FM 200 – 21
Aux. Engine: 5L23/30
Maker: Hyundai MAN B&W
Type of oil : Energol IC-HFX 303
Power: 750 kW
Amount of oil: 400 ltr.
Date of installation: October 2007

The centrifuge on aux. Engine no. 3 was installed in October 2007. After installation we opened the centrifuge after 250 running hours the first time and found the rotor completely filled with soot and other parts of dirt. The centrifuge took out approx. 2 kg of dirt. Therefore we decided to open the centrifuge every 200 – 250 running hours.

The centrifuge is installed together with their own pump and it is possible to clean the tube oil not only during operation, even when the engine is stopped and the oil has still got a temperature between 45 – 75 C° we let the centrifuge run and clean the oil.

During the last 2-month the service intervals of the used paper cartridges increased from every 300 hours to 600 – 700 hours. So we nowadays just need half the amount of paper filters, therefore we can honestly say that the installation of the Fil-Tec Rixen centrifuge unit (centrifuge FM 200-21 combined with a pump fitting to the centrifuge type GMBD 2R) was a great success and helps us to save a lot of money and time of service work.

After 2-month of working with the centrifuge we decided to install also on aux. engine no.1 and 2 a centrifuge from Fil-Tec Rixen GmbH.

Best regards

MV * HANSA RIGA*
CHIEF ENGINEER
Andrey Ivanov Ch. Eng. MV Hansa Riga

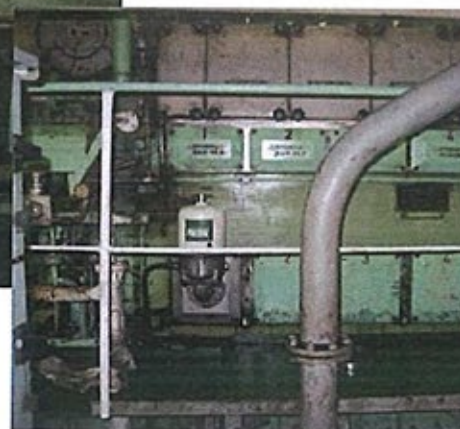
Great cost reduction through centrifuges

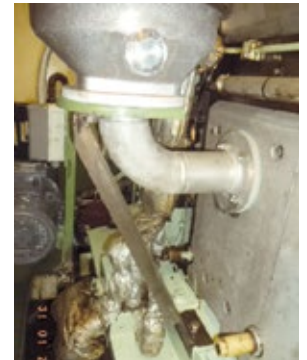
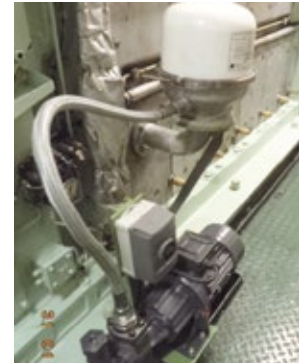

FIL-TEC RIXEN GmbH has already sold
more than 1500 plants
for ships and industry.

Qualified advice and installation help by FIL-TEC RIXEN GmbH.





FIL-TEC RIXEN GmbH Training and Demonstration Centre

FIL-TEC RIXEN GmbH set up a Training and Demonstration Centre in response to the ever more complex filtration systems and increased requirements for ships and in various industrial facilities such as those in the automotive and steel industries.

At this centre, we pass on our many years of experience to the company's specialist staff. The centre stocks a wide range of the automatic filters on the market, which are demonstrated in full function.

As part of the training, sources of disturbance can be simulated, which are then analysed by our experienced service engineers. The range includes general and technical functional problems. These also include programming errors and other issues. Monitoring possibilities within the electronic control setup can also be discussed where necessary.

On another point, we also present complex systems and demonstrate how particular filters are intended to pair up with particular facilities, how this is useful, and which filters are thus used.

Maintenance of the filter is another key part of the training. Particular effort is taken to cover monitoring and cleaning of filter elements.

We show you the best possible options available for this as well as which devices are currently on the market.

This is followed by a demonstration.

We also show you new developments from FIL-TEC RIXEN, as well as how frequently occurring failures and resulting damage can be avoided.

An overview of the training we offer:

- Structure and Features of Automatic-Backflushing-Filters for Liquids
- Localising and Removing Sources of Disturbance
- Structure and Features of Cleaning Aggregates for Lubricating Oil
- Overview of the Deployment of Complex Filter Systems
- Cleaning Filter Cartridges and Filter Elements with High-Pressure and Ultrasonic Cleaning Devices
- Other topics available on request

If you are interested, please contact us so that we can arrange an appointment which is convenient for you.

Planned duration is around 3 hours.

Of course, we take care of your physical well-being.

The FIL-TEC RIXEN Service Team

Cost reduction through mobile free-jet centrifuge

FIL-TEC RIXEN GmbH has retrofitted many main and auxiliary diesel engines with free-jet centrifuges with separate pumps in the sizes **FM 200, FM 400 and FM 600**. So far, around 2000 systems have been installed.

Doing so has proved a tremendous success for shipping companies, which have used it as a means to reduce their operating costs even further. Not only could the lubricating oil be used longer, but also the service life of components could be extended, thus lengthening the lifetime of the filter.



The range of uses of this mobile system is not just limited to the lubricating oil of main and auxiliary engines. But rather, this mobile unit can also be used for transmission oils, hydraulic oils, etc.

Thanks to its compact size (L 1000 mm x W 600 mm x H 1200 mm), it is suitable for use in operations throughout the ship.

16 hour test run of an auxiliary diesel MaK 6M25 with the lubricating oil Mobilgard M440 (Ed. Eicke).

But in order to offer shipping companies even more ways to save on operating costs, a **mobile centrifuge with pre-heating** was developed. Many auxiliary diesel engines do not have a separate oil pre-heating function or they are not connected to a separator system when the auxiliary diesel is at a standstill.

But with this mobile unit, you now have the possibility of pre-heating the oil directly from the sump and cleaning it with a free-jet centrifuge via a separate pump. Now particles such as vanadium, magnesium, calcium, zinc, etc. can be filtered out by the free-jet centrifuge at a pump pressure of 6 – 7 bar and a temperature of 70 – 80 °C. Ultimately, it's the heating of the lubricating oil that ensures the optimum treatment.

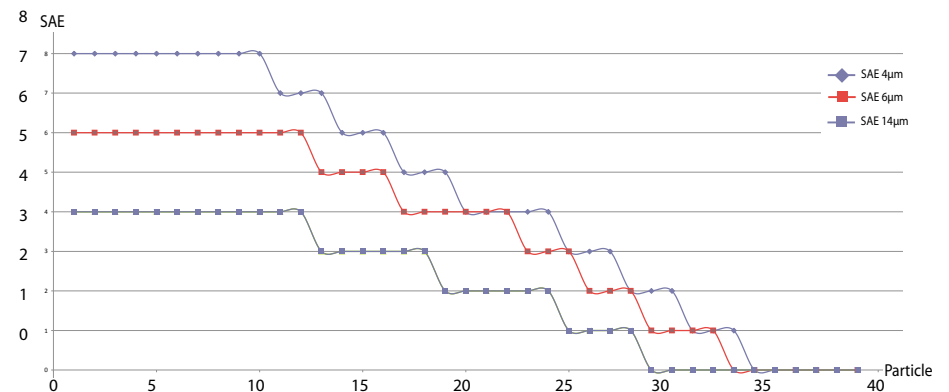
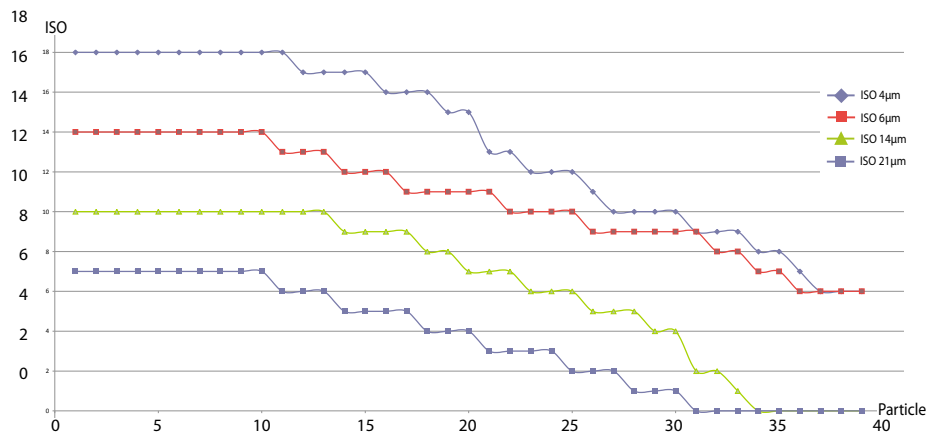



In addition, this mobile system can be supplied with a dewatering tank. A filter element has been developed which can absorb up to 4.5 litres of water and 4.2 kg of dirt.

The filtering capacity performance is measured in accordance with NAS (National Aerospace Standard) 1 and ISO 4406 13/10/7.

Therefore, you now have the ability to draw the water from the oil in an oil emulsion (e.g. capstan oil). Of course this applies equally to all engines, and transmission and hydraulic oils.

This mobile unit can be used for the following:

- Removal of particles via the free-jet centrifuge
- Removal of particles via the free-jet centrifuge and removal of water and debris via the dewatering tank at the same time

Furthermore, the system is pressure-monitored and the temperature for the pre-heater is adjustable between 30 – 90 ° C (depending on the type of oil).

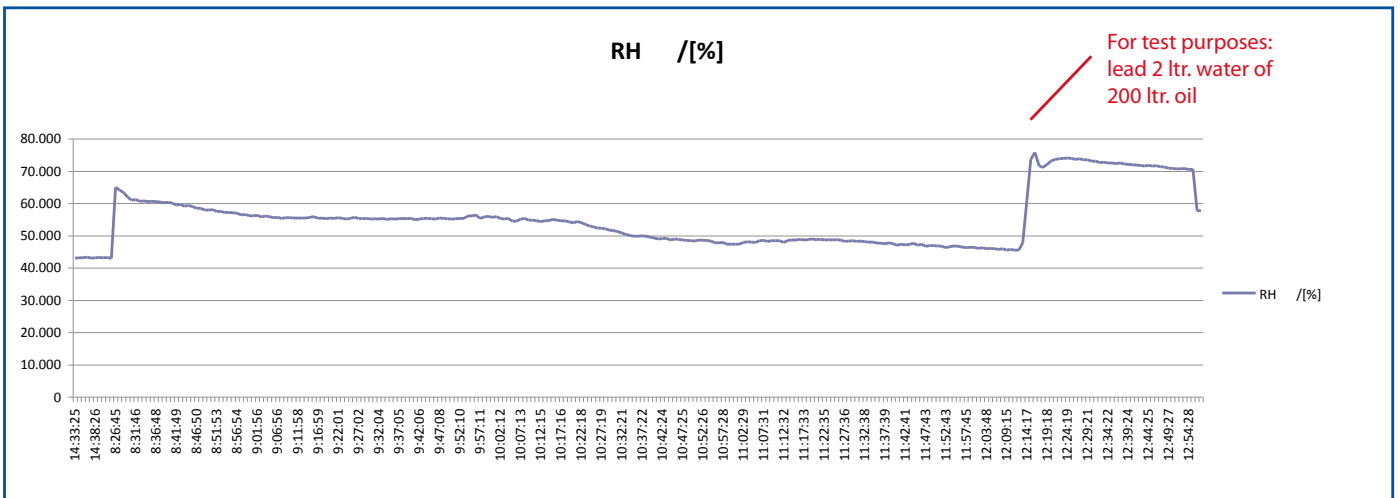

Have we aroused your interest in these measures for cutting operating costs?

If so, please contact us - we will gladly advise you.

Your FIL-TEC RIXEN team

Fil-Tec ultrasonic units – highly effective cleaning



The superior, technically best cleaning effect provided by Fil-Tec ultrasonic equipment cannot be attained by conventional methods. Even stubborn dirt in drill-holes and cavities is removed to perfection by ultrasonic treatment. No other cleaning method achieves even remotely equivalent results when it comes to cleaning filter elements.

Nevertheless, a careful check for mechanical damage to the filter elements is still necessary.

The principle of ultrasonic cleaning is based on cavitation. An ultrasonic generator produces energy and these frequencies are converted into mechanical energy by piezoelectric transducers. They produce unstable bubbles in the cleaning liquid, which implode in the liquid as a result of the movement and produce pressure pulses in turn. The resulting cavitation is

the most effective and most thorough cleaning method of all. The potential applications of ultrasonic cleaning are virtually unlimited. This deep-down cleaning is particularly beneficial for cleaning candle filters, for the cleaning action is very gentle to the material despite the cavitation.

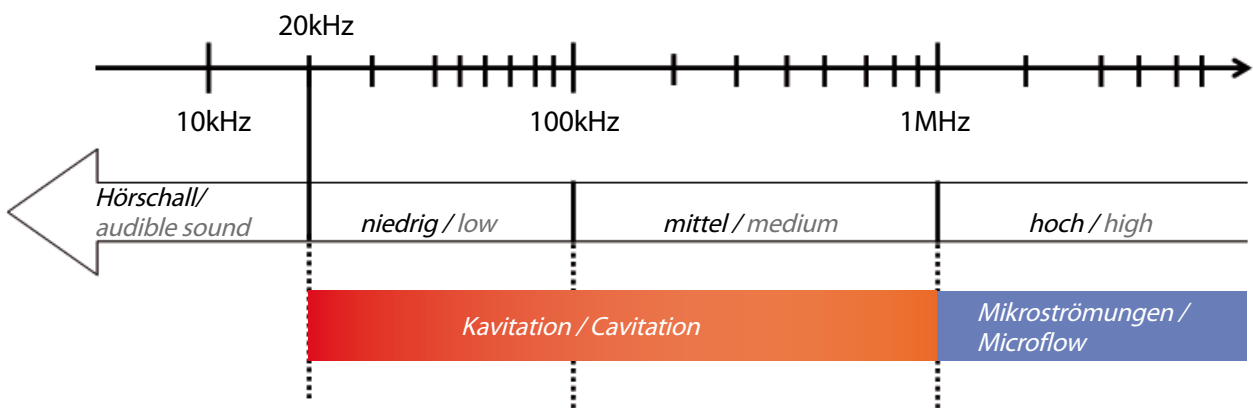

The FIL-TEC RIXEN type FT80H - FTS3300HM ultrasonic units offer virtually all of the technical know-how with a proven track record that is around today. The new devices support the ultrasonic cleaning effect better than ever before.

The service life of the equipment is extended by the sophisticated technology and types of materials used. The new design is functional and more contemporary. The virtually perfect cleaning results obtained from ultrasonic cleaning in manufacturing processes and servicing can be attributed to the Fil-Tec performance transducer systems with 37 kHz of ultrasonic power.

With the **sweep function** developed by Fil-Tec, a homogeneous sound field distribution is ensured by the continuous shifting of the sound peaks.

The **degassing function** used in the new devices efficiently accelerates the degassing of the cleaning liquid, particularly in freshly mixed baths. The automatic degassing mode before the start of cleaning or degassing for certain tasks can be set manually. During heavy-duty continuous operation, it becomes immediately obvious that the new units with their practical features have no trouble at all meeting the needs in the field.

Technical Data Ultra Sonic Cleaning

Type:	Table - Units			FTS500HM	FTS700HM
	FT80H	FT100H	FT120H		
Tank max. Volume (liter)	9,4	9,5	12,5	28	76
Tank working Volume (liter)	7	7	10	18	51
Tank Internal Dimensions (mm)	505x137x150	300x240x150	300x240x200	505x300x200	550x300x470
Machine External Dimensions (mm)	568x179x264	365x278x264	365x278x321	568x340x321	640x540x730
Basket Internal Dimensions (mm)	455x106x75	255x200x80	250x190x115	455x250x115	500x225x240
Weight (kg)	6,4	5,9	7,5	11	43
Power Supply	230-240 V/N/PE	230-240 V/N/PE	230-240 V/N/PE	230-240 V/N/PE	230-240 V/N/PE or 3x400 V/N/PE or 3x440 V/N/PE 50/60 Hz
Ultrasonic Frequency (kHz)	37	37	37	37	37
Sweep
Pulse
max. overall Power (W)	750	600	1000	1500	2750
effective Ultrasonic Power (W)	600	600	800	1200	500
max. Ultrasonic Power (W)	600	550	800	1200	1000
Heating Power (W)	600	400	800	1200	2200
Cover
Basket
Heating
Drain

The special functions, features and benefits

The FIL-TEC RIXEN **type FT80H - FTS3300HM ultrasound** devices include a range of 9 sizes available with tank capacities of 9 to 257 litres. They are equipped with efficient 37kHz ultrasonic transducers of the latest generation.

- The cleaning process is supported by a dry-run protected heater (optional)
- The control panel is user-friendly, concise and designed so that no liquid can penetrate into the electronics
- The cleaning tanks are made of cavitation-resistant stainless steel
- The switchable sweep function uses frequency modulation to ensure an optimum distribution of the sound field in the cleaning liquid
- The fill line is integrated
- The cleaning time is shown both as the set time and remaining time in an LED display
- The rotary switch for the pre-selection of the cleaning time can be set to continuous duty or short-time duty
- The de-gassing function allows for faster de-gassing of the cleaning liquid. Another advantage is the timed „Auto de-gas“ function for efficient de-gassing in fresh cleaning liquid
- For safety reasons, the device switches off automatically after 12 hours
- Temperature settings from 30 ° to 80 ° C in increments of 5 ° can be selected with the rotary switch. The setpoint and actual value of the liquid temperature is clearly visible in an LED display
- The cleaning process can be switched on at any time manually or is temperature-controlled



Devices 2014

Marine - Units			Seitenschallgerät
FTS1600HM	FTS2000HM	FTS3300HM	FTS1700HM
165	208	383	187
100	126	257	134
650x550x520	820x500x520	1150x550x620	410x650x720
740x730x730	910x740x730	1240x800x890	615x900x1040x
585x410x240	755x410x240	1075x460x360	360x560x240
62	69	121	75
230-240 V/N/PE or 3x400 V/N/PE or 3x440 V/N/PE 50/60 Hz	230-240 V/N/PE or 3x400 V/N/PE or 3x440 V/N/PE 50/60 Hz	3x400 V/N/PE or 3x440 V/N/PE 50/60 Hz	230-240 V/N/PE or 3x400 V/N/PE or 3x440 V/N/PE 50/60 Hz
37	37	37	45
•	•	•	•
•	•	•	•
3050	3250	8050	3350
800	1000	2000	1000
1600	2000	4000	4000
2200	2200	6000	2300
•	•	•	•
•	•	•	•
•	•	•	•
•	•	•	•



Candle filter before cleaning in ultrasonic bath



Candle filter after cleaning in ultrasonic bath



Example of use
Cylinder head cleaning:

Before



After cleaning in ultrasonic bath

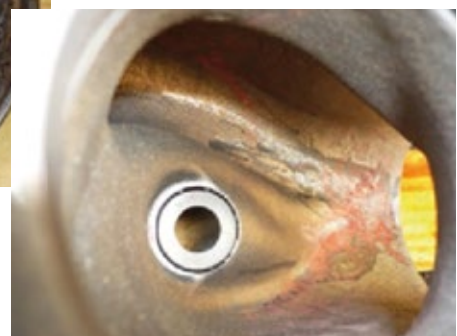

Fil-Tec filter detergents

FT31 Degreaser/ ultrasonic cleaning

Fil-Tec FT31 is a liquid detergent designed for a broad spectrum of applications. It can be used for virtually all cleaning and degreasing tasks.

FT31

- ✓ is water-based
- ✓ is mildly alkaline
- ✓ has a boiling point in excess of 100°C
- ✓ is not environmentally hazardous
- ✓ Standard container 33 kg

FT31 is very economical to use for slightly greasy substances as the mixing ratio is 1:100. Since it is classified as a non-hazardous product, FT31 is not subject to any transport restrictions.



FT200 for ultrasonic cleaning

The detergent FT200 has been developed for use in ultrasonic units and is ideally suited to cleaning all steel and stainless steel parts.

- ✓ Long lifetime in the bath
- ✓ Temperature-stable
- ✓ Extends the cleaning intervals for the candle filters
- ✓ High dilution with water, therefore extremely economical
- ✓ De-emulsifying
- ✓ Standard container 33 kg



Filter fabric 10µm (mesh 660/63) before cleaning

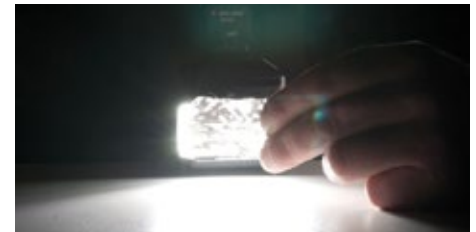

Filter fabric (mesh 660/63) after cleaning



FT440 Oil and soot sludge remover

FT440 is a high performance solvent mixture for dissolving grease and oil sludge, and is particularly suitable for pre-cleaning of candle filters and filter elements (fuel, lubricating oil and hydraulic oil). Furthermore, it is used for cleaning separators and housings, and can also be used in immersion baths.

- ✓ is a very fast-acting degreaser
- ✓ can be disposed of in the sludge tank
- ✓ extremely fast cleaning results
- ✓ long lifetime in immersion bath
- ✓ Standard container 33 kg



Fil-Tec cleaning tools

Tools for cleaning with compressed air and high-pressure cleaners

1. Lances for cleaning with compressed air

Type: FT1MS

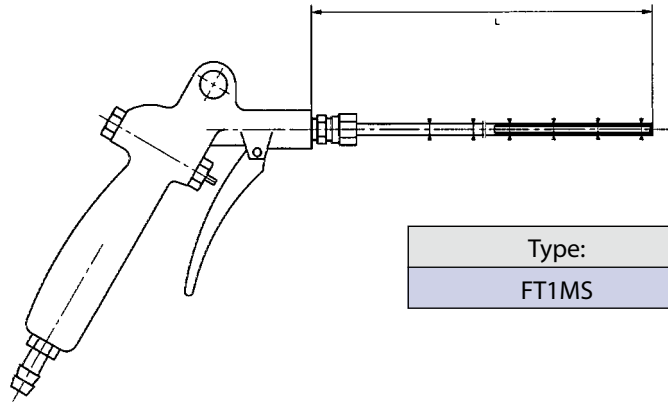

Type:	L1 (mm)	L2 (mm)	L3 (mm)
FT1MS	300	600	900

Cleaning lance for connection to the compressed air supply with a hose (I.D. 10 mm / 6 bar), the FTMS cleaning lance is used for the air-cleaning of installed mantle elements. The dirt particles that have collected on the outside of the mantle element are blown off by compressed air from the clean side out.

2. Spray gun for cleaning wire mesh screw-in or plug-in candles

Type FT5.01

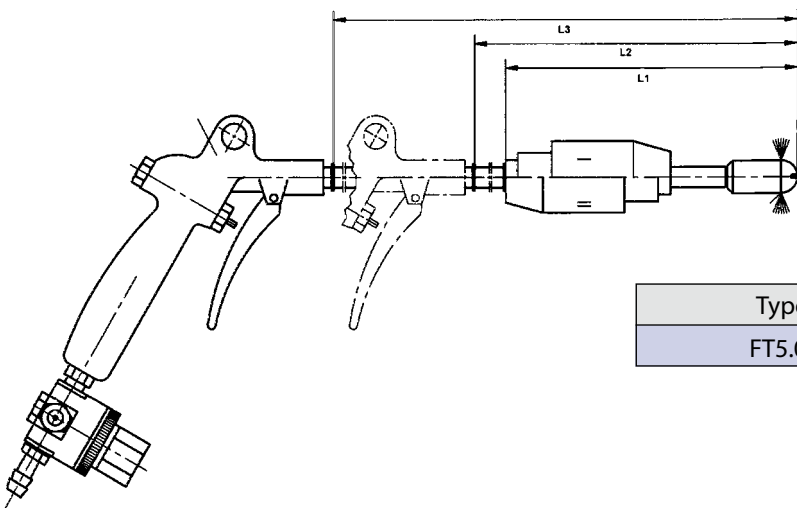

Type:	L1 (mm)	L2 (mm)	L3 (mm)
FT5.01	300	600	900

Cleaning lance for connection to the compressed air supply with a hose (I.D. 10 mm / 6 bar), the FT5.02 cleaning lance is used for the air-cleaning of wire mesh screw-in or plug-in candles. The dirt particles that have collected on the outside of the candles are blown off by compressed air from the clean side out.

3. Lance with rotating nozzle for the cleaning of wire mesh screw-in or plug-in candles

Type: FT2

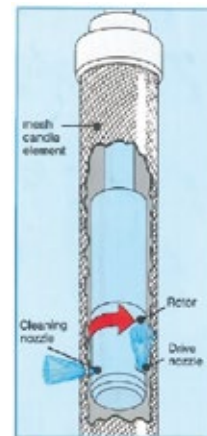
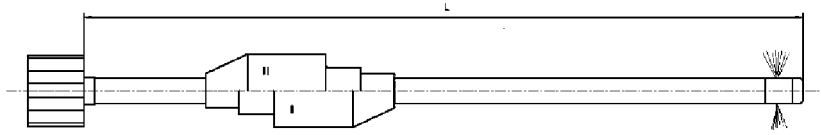

Type:	L1 (mm)	L2 (mm)	L3 (mm)
FT2	300	600	900

Cleaning lance FT2 with rotating nozzle for rinsing out wire mesh plug-in or screw-in candles. The lance is inserted into the candle and the open end is sealed depending on the type (I = plug-in candle, II = screw-in candle). Through the combined action of the rotating nozzle and the water pressure (high-pressure cleaner), the dirt particles are washed out of the candle mesh from the clean side (inside) out.

4. Cleaning lance with fan nozzle

FT2FS

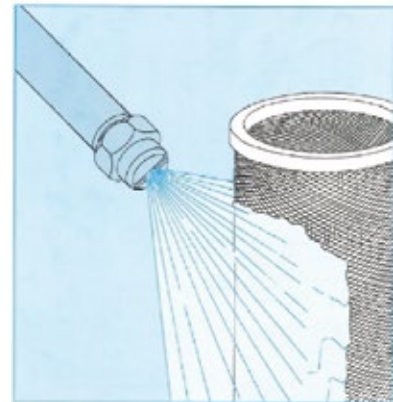
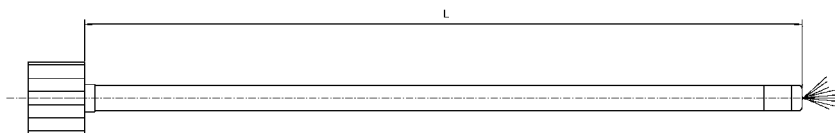

Type:	L1 (mm)	L2 (mm)	L3 (mm)
FT2FS	300	600	900

Cleaning lance FT2FS with fan nozzle for washing filter elements, such as basket elements, ring elements and pleated elements.

CAT FINES – a great risk

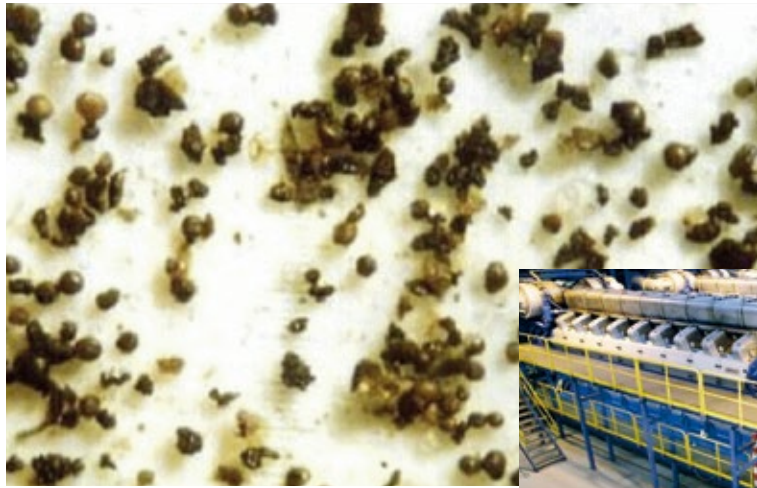

What are Cat Fines?

These are catalysers that are added to the crude oil in the refinery process of catalytic cracking. This procedure permits large, high-boiling hydrocarbon molecules to be

split into many smaller, low-boiling ones. Only this permits the production of fuels such as diesel, gasoline, etc. The Cat Fines are made of aluminium and silicon compounds at a size of ~ 10 - 50 µ.

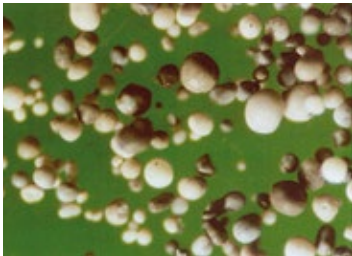

Chemical composition: Al_2O_3, SiO_2
 Size: 10 – 50 µm
 Weight dry: 1,2 bis 2,3 g/cm³
 Weight of Cat Fines: 2,5 bis 3,5
 Mechanical condition: hard, abrasive

According to our examinations, the greatest share is at ~ 10 µ. The properties of the surface are very porous and therefore very difficult to separate from the fuel to be prepared.

Because of stricter environmental specifications in specific driving areas according to IMO, the permitted emission of NO_2

and SO_2 is only 0.1 percent by weight today. From 2015 onwards, this will apply to the North and Baltic seas as well.

Because of this requirement, aluminium sulphate is added to the mineral oil at large scopes or high dosages.

Among others for reasons of cost, the refineries are interested in removing the mineral from the fuel to return it to the refinery process. Additionally, Cat Fines have a highly abrasive effect in the end products, thus posing a great risk for motors. The motor manufacturers set up directives to be complied with the specification of max. 15 – 20 ppm.

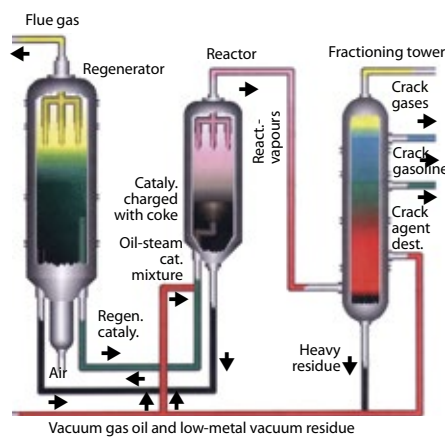
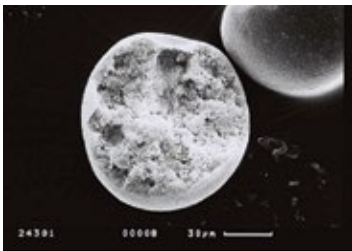

Catalytic fluid bed cracking

A much better conversion result than in the thermal procedure can be reached with catalytic cracking. Here, a dust-shaped catalyst that acts like a liquid in a steam-gas flow is used. Catalysts are substances that act just by being present, promoting, accelerating and directing chemical reactions

in a specific direction without changing themselves. During cracking, carbon will deposit on the catalyst as coke and make the catalyst lose its effect. Therefore, the coke is burned off in the downstream regenerator so that the catalyst can be used again.

When these values are exceeded, high wear often occurs at injection elements such as pumps and nozzles in very short times, but piston rings and bushes can also exceed the permissible wear very quickly.

It has been shown that this may happen in less than 200–300 operating hours.

What to do to reduce this high wear and the connected costs and downtimes?

Under the management of Dipl.-Ing. Fritz Rixen, FIL-TEC RIXEN GmbH has been dealing with this problem for 30 years. In the course of development, many ships had "filtrators" installed (the name is made up of "filter" and "separator"). For cost reasons and through improvement

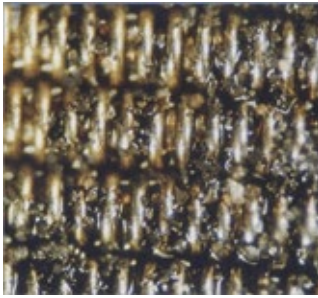

Incoming filter tissue at 10 µm



Same filter tissue 10 µm, cleaned

of filter systems, the filtrators are only used in small scopes anymore.

The best reduction of Cat Fines can only be controlled via a **filter system**, however. All other options can only go a small way towards reaching the result.

A filter is monitored via a pressure difference indicator. The pressure difference between the entry and exit precisely measures this value and cleans the automatic filter independently. In double filters, this cleaning must be done manually or optionally with an ultrasound device. All other system work is performed according to time, which is adjustable.

Particle removal by

- 1 Centrifuging
- 2 Filtration (25 µ filter)
- 3 Centrifuging and filtration

3a: Centrifuging + 10 µm filtration
 2a: 10 µm 660/63 filter tissue

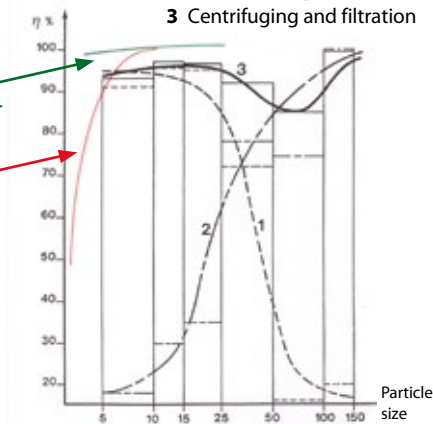

The filter can be used in heavy oil operation or MDO operation and keeps this contamination back at 100% certainty.

About 30 years ago, a tissue was developed specifically for these cases. It meets these demands today as well.

The tissue has an absolute mesh of 10 µ, at a nominal mesh of 5 µ.

It is very important that in spite of this extremely fine mesh, a free cross-section of ~ 20 % is still reached. These high-quality tissues are produced **ONLY in Germany and used ONLY by specialists**, never by low-cost manufacturers.

These tissues for filter elements are partially recommended by motor manufacturers, but not mandatory. Tissue designation: 660/63

We, FIL-TEC RIXEN GmbH, are also able to configure any fuel preparations upstream of the machine together with the operator so that they meet current and future demands.

Unfortunately, we often find defective filter elements from low-cost manufacturers in use for filtration during our

service deployments – both in automatic fuel filters and in downstream policing filters or indicator filters.

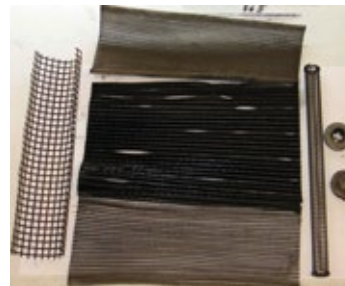

The uncoiled pleats in the illustration show large tears that no longer warrant the requirements for separating Cat Fines at 10 µm and thus may cause enormous damage. No differential pressure will build up

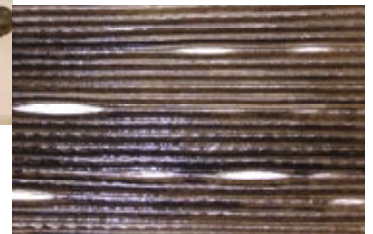

We, as specialists with our own production in Germany, will gladly help you avoid damage and costs. This service is offered only by companies with the corresponding experience and great long-term know-how.

Various trading companies are unable to offer this.

A summary from the ships-engineer journal
with comments from **FIL-TEC RIXEN GmbH**

Engine damages increase more and more

One of the classics are damaged turbo-chargers. The aggregates takes often damages, as the maintenance of the **lubrication oil system** of the main engine is insufficient. **Filter candles** aren't changed in time or the filter housings are not cleaned, emphasizes the properly average expert Herbert Jentz. „If the lubrication oil of the engine is in poor condition, the turbochargers are the first to take damages“ he said. (...)

Comment from **FIL-TEC RIXEN GmbH**:

In cases like these, the filter elements were often purchased from **“ONLY TRADERS”** with an absolutely lack of technical knowledge. Further the elements are usually a cheap alternative, purchased from China e.g., and do not satisfy the requirements of the engine manufacturers. Consequently serious damages are preprogrammed.

Examples for cheap alternatives

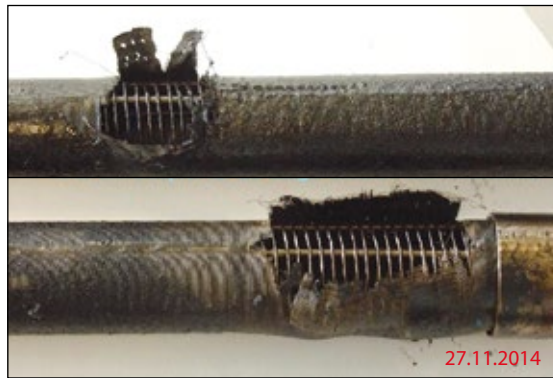

Here we have a sample of saucer eyed weld



So we found the filter candle,
cap- and end piece partly loose.



We, the company **Fil-Tec Rixen GmbH**, use only certified meshes.

Our elements are **MADE IN GERMANY ONLY!!!**



Through decades of experience and development, we have gained the required technical know-how to offer high quality products and are always interested to help and find solutions for each kind of technical problem the inspection or superintendent may have!

How to find us:



Company Information:

Title

Image-Brochure
The Specialists for Filters
in Marine and Industry
July, 2016

Text and Design

Oliver Rixen
Oliver Kreienkamp

Graphic Design

Sachsenwald Druckdesign

Pictures

Bernhard Claßen
i-stockphoto
fotolia

Edited by

FIL-TEC RIXEN GmbH
Dipl.-Ing. Oliver Rixen
(responsible)
Osterrade 26
Phone +49 (0) 40.656 856 - 0
Fax +49 (0) 40.656 57 31
info@fil-tec-rixen.com

Managing Director

Dipl.-Ing. Oliver Rixen

The information presented on these pages was taken from sources that we believe are reliable. All rights are reserved. We cannot, however, guarantee its accuracy and completeness. No responsibility is taken for the correctness of this information. We assume no liability for any errors or omissions or resulting financial losses. Reproductions, especially reprints and copies or publications, are allowed only with written permission from FIL-TEC RIXEN GmbH. Exclusive venue is Hamburg.



Complete Filters

Filter Elements

Spare Parts

Accessories

Centrifuges

Cleaning Agents

Repair

Installation

FIL-TEC-RIXEN GmbH

Osterrade 26 D-21031 Hamburg

Phone +49 (0) 40-656 856 - 0

Fax +49 (0) 40-656 57 31

info@fil-tec-rixen.com

www.fil-tec-rixen.com

